

SSI700 Inverter Mini Vector

SSI700



User Manual - EN

Preface

Thank you for purchasing the SSI700 series AC drive developed by SSINVERTER Co., Ltd.

The SSI700 series AC drive is a general-purpose current vector control AC drive. It is an upgrade product based on SSI700 and can implement the control of asynchronous motor. It increases the user programmable function, back ground monitoring software and communication bus function. It is used to drive various automation production equipment involving textile, paper-making, wiredrawing, machine tool, packing, food, fan and pump. This manual describes the correct use of the SSI700 series AC drive, including selection, parameter setting, commissioning, maintenance & inspection. Read and understand the manual before use and forward the manual to the end user.

Notes

- The drawings in the manual are sometimes shown without covers or protective guards. Remember to install the covers or protective guards as specified first, and then perform operations in accordance with the instructions.
- The drawings in the manual are shown for description only and may not match the product you purchased.
- The instructions are subject to change, without notice, due to product upgrade, specification modification as well as efforts to increase the accuracy and convenience of the manual.
- Contact our agents or customer service center if you have problems during the use.

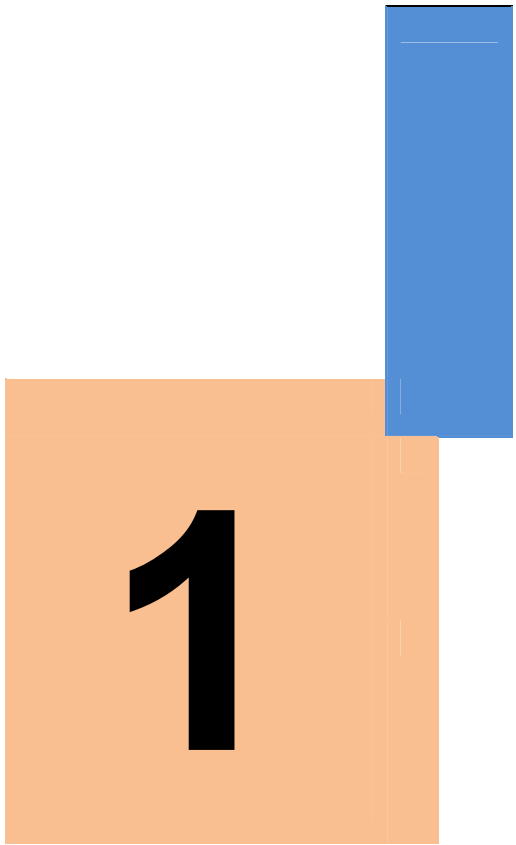

Safety Information and Precautions

Introduction

Compared with SSI700, the SSI900 series AC drive incorporates the following improvements:

1) Multiple voltage classes

It provides coverage of single-phase 220 V, three-phase 220 V, three-phase 380 V .

2) Control of asynchronous motor

It supports vector control of three-phase AC asynchronous motor.

3) Diversified control modes

It supports control modes, namely, sensorless flux vector control (SFVC) and V/F control.

4) communication protocols

It supports communication via Modbus-RTU .

5) Other new functions

The newly added functions of the SSI700 series AC drive are described as below:

Function	Description
Virtual I/O	It can implement various simple logic functions.
Rapid current limit	It helps to avoid frequent occurrence of overcurrent faults of the AC drive.

Function	Description
Restoring user parameters	It allows you to save or restore the parameters set by yourself.
Higher-accuracy AI/AO	The AI/AO accuracy can reach almost 20 mv via factory correction or on-site correction.
Customized parameter display	You can customize the parameters that need to be displayed.
Modified parameter display	You can view the modified parameters.
Operation selection at fault occurrence	You can select the reaction of the AC drive to a fault occurring, based on the actual need. The reactions are as below: <ul style="list-style-type: none"> • Coast to stop • Decelerate to stop • Continue to run You can also select the frequency at which the AC drive continues to run.
PID parameters switchover	Two groups of PID parameters can be switched over via terminals or can be automatically switched over according to deviation.
PID feedback loss detection	The PID feedback loss value can be set to realize PID protection.
DI/DO positive or negative logic	You can set the DI/DO positive or negative logic.
DI/DO response delay	You can set DI/DO response delay time.
Power dip ride through	It ensures that the AC drive continues to run for a short time when an instantaneous power failure or sudden voltage reduction occurs.
Timing operation	The AC drive supports timing operation for 6500 minutes at maximum.

Product Checking

 3

Upon unpacking, check:

- Whether the nameplate model and AC drive ratings are consistent with your order. The box contains the AC drive, certificate of conformity, user manual and warranty card.
- Whether the AC drive is damaged during transportation. If you find any omission or damage, contact Ssinverter or your supplier immediately.

First-time Use

For the users who use this product for the first time, read the manual carefully. If in doubt concerning some functions or performances, contact the technical support personnel of Ssinverter to ensure correct use.

CE Mark

The CE mark on the declares that the AC drive complies with the European low voltage directive (LVD) and EMC directive.

The SSI700 series AC drive complies with the following LVD and EMC directives and standards:

The SSI700 series AC drive complies with the requirements of standard IEC/EN 61800-3 on the condition of correct installation and use by following the instructions in chapter 7.

Contents

Preface	1
Introduction	2
Chapter 1 Safety Information and Precautions	
1.1 Safety Information	1
1.2 General Precautions	3
Chapter 2 Product Information	
2.1 Designation Rules and Nameplate of the SSI700	1
2.2 Components of the SSI700	1
2.3 Technical Specifications	1
2.4 Peripheral Electrical Devices and System Configuration	3
Chapter 3 Mechanical and Electrical Installation	
3.1 Mechanical Installation	1
3.2 Electrical Installation	2
Chapter 4 Operation, Display and Application Examples	
4.1 Operation Panel	1
4.2 Viewing and Modifying Function Codes	2
4.3 Definition and Operation of the Multifunction Key (APP)	3
4.4 Viewing Status Parameters	3
4.5 Starting or Stopping the AC Drive	6
4.6 Setting the Running Frequency	11
4.7 Setting and Auto-tuning of Motor Parameters	17
4.8 Use of DI Terminals	19
4.9 Use of DO Terminals	20
4.10 Use of AI Terminals	20

4.11 Use of AO Terminals	20
4.12 Use of Serial Communication	21
4.13 Password Setting	21
4.14 Parameter Saving and Default Setting Restoring	22
Chapter 5 Function Code Table	
5 Standard Function Parameters	1
Chapter 6 Description of Function Codes	
Group P0: Basic Parameters	1
Group P1: Motor 1 Parameters	9
Group P2: Vector Control Parameters	10
Group P3: V/F Control Parameters	13
Group P4: Input Terminals	15
Group P5: Output Terminals	23
Group P6: Start/Stop Control	27
Group P7: Operation Panel and Display	32
Group P8: Auxiliary Functions	37
Group P9: Fault and Protection	47
Group 10: Process Control PID Function	53
Group 11: Swing Frequency, Fixed Length and Count	58
Group 12: Multi-Reference and Simple PLC Function	60
Group 13: Point-point Communication	63
Group 16: User Password	63
Group 17: Torque Control and Restricting Parameters	64
Chapter 7 EMC	
7.1 Definition of Terms	1
7.2 Introduction to EMC Standard	1
7.3 Selection of Peripheral EMC Devices	2
7.4 Shielded Cable	3
7.5 Solutions to Common EMC Interference Problems	5
Chapter 8 Selection and Dimensions	
8.1 Electrical Specifications of the SSI700	1
8.2 Physical Appearance and Overall Dimensions of the SSI700	1
8.3 Physical Dimensions of External Operation Panel	2
8.4 Selection of Braking Resistor	3
Chapter 9 Maintenance and Troubleshooting	
9.1 Routine Repair and Maintenance of the SSI700	1
9.2 Warranty Agreement	2
9.3 Faults and Solutions	2
9.4 Common Faults and Solutions	5

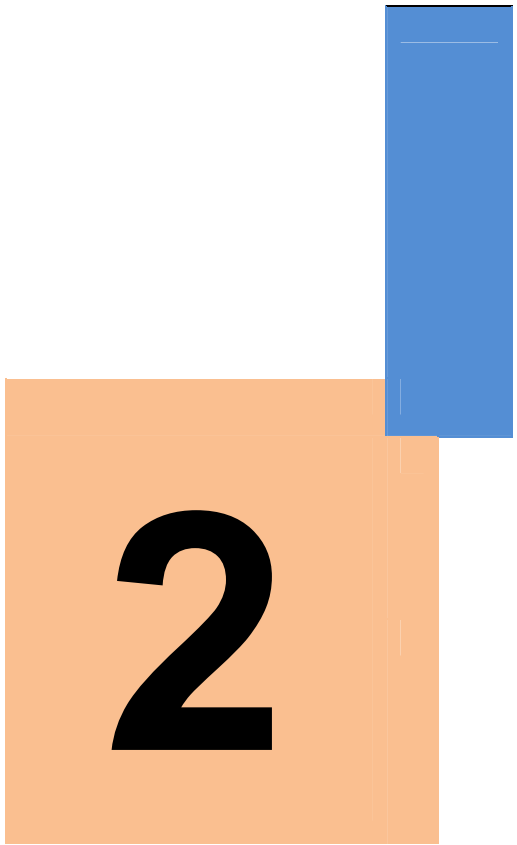

Product Information

Chapter 2 Product Information

2.1 Designation Rules and Nameplate of the SSI700

Figure 2-1 Designation rules and nameplate of the SSI700

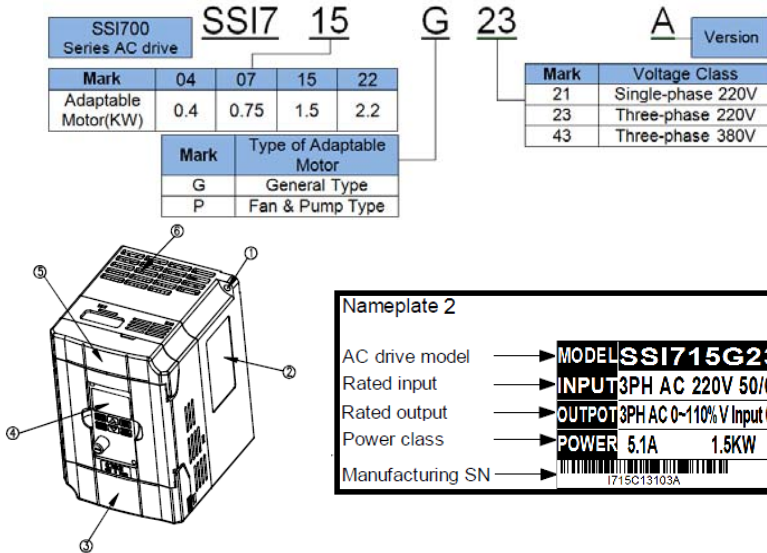

2.2 Components of the SSI700

The SSI700 series AC drives have two housing types, plastic housing according to different voltage and power classes.

2.3 Technical Specifications

Table 2-1 Technical specifications of the SSI700

Item	Specifications	
Standard functions	Maximum frequency	<ul style="list-style-type: none"> • Vector control: 0–320 Hz • V/F control: 0–3200 Hz
	Carrier frequency	0.5–16 kHz The carrier frequency is automatically adjusted based on the load features.
	Input frequency resolution	Digital setting: 0.01 Hz Analog setting: maximum frequency x 0.025%
	Control mode	<ul style="list-style-type: none"> • Sensorless flux vector control (SFVC) • Voltage/Frequency (V/F) control
	Startup torque	• G type: 0.5 Hz/150% (SFVC)
	Speed range	1:100 (SFVC)
	Speed stability accuracy	• ± 0.5% (SFVC)
	Overload capacity	• G type: 60s for 150% of the rated current, 3s for 180% of the rated current
	Torque boost	<ul style="list-style-type: none"> • Fixed boost • Customized boost 0.1%–30.0%
	V/F curve	<ul style="list-style-type: none"> • Straight-line V/F curve • Multi-point V/F curve • N-power V/F curve (1.2-power, 1.4-power, 1.6-power, 1.8-power, square)

	Item	Specifications
Standard functions	V/F separation	Two types: complete separation; half separation
	Ramp mode	<ul style="list-style-type: none"> • Straight-line ramp • S-curve ramp Four groups of acceleration/deceleration time with the range of 0.0–6500.0s
	DC braking	DC braking frequency: 0.00 Hz to maximum frequency Braking time: 0.0–36.0s Braking action current value: 0.0%–100.0%
	JOG control	JOG frequency range: 0.00–50.00 Hz JOG acceleration/deceleration time: 0.0–6500.0s
	Onboard multiple preset speeds	It implements up to 16 speeds via the simple PLC function or combination of DI terminal states.
	Onboard PID	It realizes process-controlled closed loop control system easily.
Individualized functions	Auto voltage regulation (AVR)	It can keep constant output voltage automatically when the mains voltage changes.
	Overvoltage/Overcurrent stall control	The current and voltage are limited automatically during the running process so as to avoid frequent tripping due to overvoltage/overcurrent.
	Torque limit and control	It can limit the torque automatically and prevent frequent over current tripping during the running process.
RUN	Running command source	<ul style="list-style-type: none"> • Operation panel • Control terminals • Serial communication port You can perform switchover between these sources in various ways.
	Frequency source	There are a total of 10 frequency sources, such as digital setting, analog voltage setting, analog current setting, pulse setting and serial communication port setting. You can perform switchover between these sources in various ways.
	Auxiliary frequency source	There are ten auxiliary frequency sources. It can implement fine tuning of auxiliary frequency and frequency synthesis.
	Input terminal	5 digital input (DI) terminals, one of which supports up to 100 kHz high-speed pulse input 2 analog input (AI) terminals, one of which only supports 0–10 V voltage input and the other supports 0–10 V voltage input or 4–20 mA current input.
	Output terminal	1 high-speed pulse output terminal (open-collector) that supports 0–100 kHz square wave signal output 1 digital output (DO) terminal 1 relay output terminal 1 analog output (AO) terminal that supports 0–20 mA current output or 0–10 V voltage output
Display and operation	LED display	It displays the parameters.
	Key locking and function selection	It can lock the keys partially or completely and define the function range of some keys so as to prevent mis-function.
	Protection mode	Motor short-circuit detection at power-on, output phase loss protection, overcurrent protection, overvoltage protection, undervoltage protection, overheat protection and overload protection
Environment	Installation location: Indoor, free from direct sunlight, dust, corrosive gas, combustible gas, oil smoke, vapour, drip or salt. Altitude: Lower than 1000 m Ambient temperature: -10°C to +40°C (de-rated if the ambient temperature is between 40°C and 50°C) Humidity: Less than 95%RH, without condensing Vibration: Less than 5.9 m/s ² (0.6 g) Storage temperature: -20°C to +60°C IP level: IP20 Pollution degree: PD2 Power distribution System: TN , TT	

2.4 Peripheral Electrical Devices and System Configuration



When the SSI700 is used to control the synchronous or asynchronous motor, forming a control system, it is necessary to install various electrical devices on the input and output sides of the AC drive to ensure the system safety and stability.

Figure 2-2 System configuration of three-phase 220 V/380 V voltage class, 2.2 Kw and above

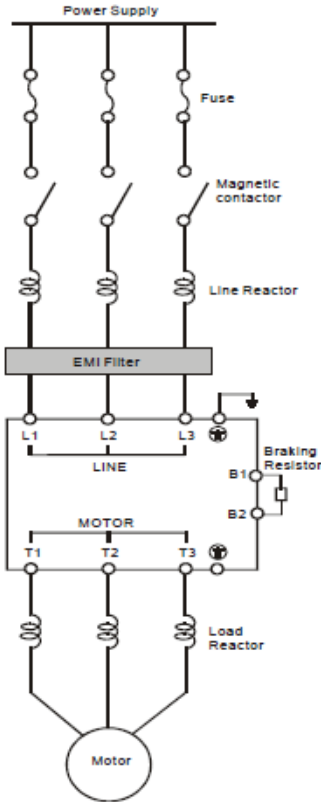

Items	Explanations
Power supply	Please follow the specific power supply requirement
Fuse/NFB	There may be inrush current during power up.
Magnetic contactor (Optional)	Please do not use a Magnetic contactor as the I/O switch of the AC drive, this will reduce the operating life cycle of the AC drive.
AC Reactor (Optional)	To improve the power factor. An AC Reactor may be necessary when capacity is above 1000kVA, and the wiring distance is within 10m.
EMI filter (Optional)	To reduce the electromagnetic interference.
Braking Resistor (Optional)	Used to reduce stopping time of the motor.

2.4.1 Description of Peripheral Electrical Devices

Table 2-2 Description of peripheral electrical devices

Part	Mounting Location	Function Description
MCCB	Power receiving side	Interrupt the power supply when overcurrent occurs on down stream devices
Contactor	Between MCCB and AC drive input side	Start and stop the AC drive. Do not start and stop the AC drive frequently by switching the contactor on and off (less than twice per minute) nor use it to directly start the AC drive.
AC input reactor	AC drive input side	<ul style="list-style-type: none"> • Improve the power factor of the input side. • Eliminate the higher harmonics of the input side effectively and prevent other devices from being damaged due to distortion of the voltage waveform. • Eliminate the input current unbalance due to unbalance between the power phases.

Part	Mounting Location	Function Description
EMC Input filter	AC drive input side	<ul style="list-style-type: none"> • Reduce the external conduction and radiation interference of the AC drive. • Decrease the conduction interference flowing from the power end to the AC drive and improve the anti interference capacity of the AC drive.
AC output reactor	Between AC drive output side and the motor, close to the AC drive	<p>The output side of the AC drive generally has much higher harmonics. When the motor is far from the AC drive, there is much distributed capacitance in the circuit and certain harmonics may cause resonance in the circuit, bringing about the following two impacts:</p> <ul style="list-style-type: none"> • Degrade the motor insulation performance and damage the motor in the long run. • Generate large leakage current and cause frequent AC drive protection trips. <p>If the distance between the AC drive and the motor is greater than 50 m, install an AC output reactor.</p>

1) Do not install the capacitor or surge suppressor on the output side of the AC drive.

Otherwise, it may cause faults to the AC drive or damage to the capacitor and surge suppressor.

2) Inputs/Outputs (main circuit) of the AC drive contain harmonics, which may interfere with the communication device connected to the AC drive. Therefore, install an anti-interference filter to minimize the interference.

3) For more details on peripheral devices, refer to related selection manual.

2.4.2 Description of Optional Parts

The optional parts include braking unit of different functions and external operation panel, etc. If any optional part is required, specify it in your order.

Table 2-3 Optional parts of the SSI700

Name	Model	Function	Remark
Internal braking unit	AC drive model followed	The models of single-phase (0.4–2.2 kW) and three-phase (0.75–15 kW) are installed with the internal braking unit as standard configuration.	Internal braking unit.
External LED operation panel	panel	It supports LED display and operations.	It applies to the SSI700 series AC drives.



Mechanical and Electrical Installation

Chapter 3 Mechanical and Electrical Installation

3.1 Mechanical Installation

3.1.1 Installation Environment Requirements

Item	Requirements
Ambient temperature	-10°C to +50°C
Heat dissipation	Install the AC drive on the surface of an incombustible object, and ensure that there is sufficient space around for heat dissipation. Install the AC drive vertically on the support using screws.
Mounting location	Free from direct sunlight, high humidity and condensation Free from corrosive, explosive and combustible gas Free from oil dirt, dust and metal powder
Vibration	Less than 0.6 g Far away from the punching machine or the like
Protective enclosure	The SSI700 series AC drives of plastic housing are the whole unit built-in products operated through remote control and need to be installed in the final system. The final system must have the required fireproof cover, electrical protective cover and mechanical protective cover, and satisfy the regional laws & regulations and related IEC requirements.

3.1.2 Installation Clearance Requirements

The clearance that needs to be reserved varies with the power class of the SSI700, as shown in the following figure.

Figure 3-1 Clearance around the SSI700 for installation

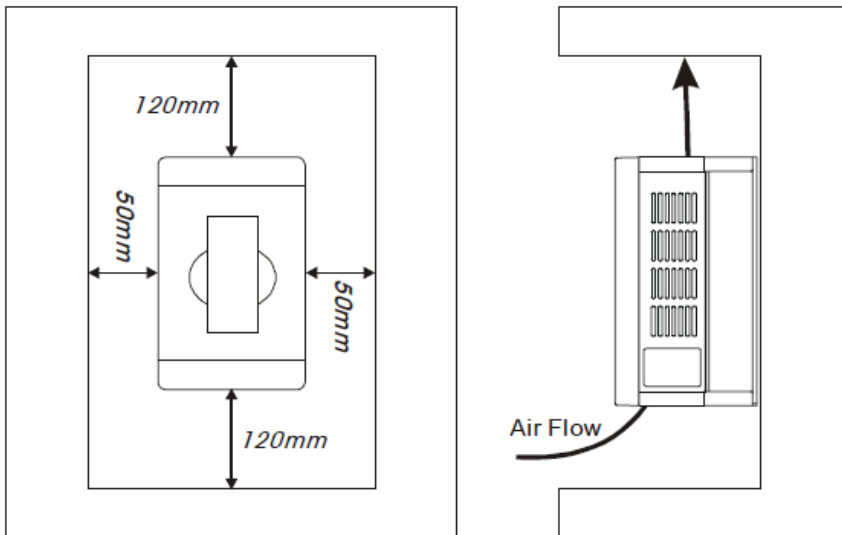

The SSI700 series AC drive dissipates heat from the bottom to the top. When multiple AC drives are required to work together, install them side by side.

For application installing multiple AC drives, if one row of AC drives need to be installed above another row, install an insulation guide plate to prevent AC drives in the lower row from heating those in the upper row and causing faults.

■ Installation Precautions

2

- 1) Reserve the installation clearances as specified in Figure 3-1 to ensure sufficient space for heat dissipation. Take heat dissipation of other parts in the cabinet into consideration.
- 2) Install the AC drives upright to facilitate heat dissipation. If multiple AC drives are installed in the cabinet, install them side by side. If one row of AC drives need to be installed above another row, install an insulation guide plate .
- 3) Use incombustible hanging bracket.

3.2 Electrical Installation

3.2.1 Description of Main Circuit Terminals

- Description of Main Circuit Terminals of Three-phase AC drive

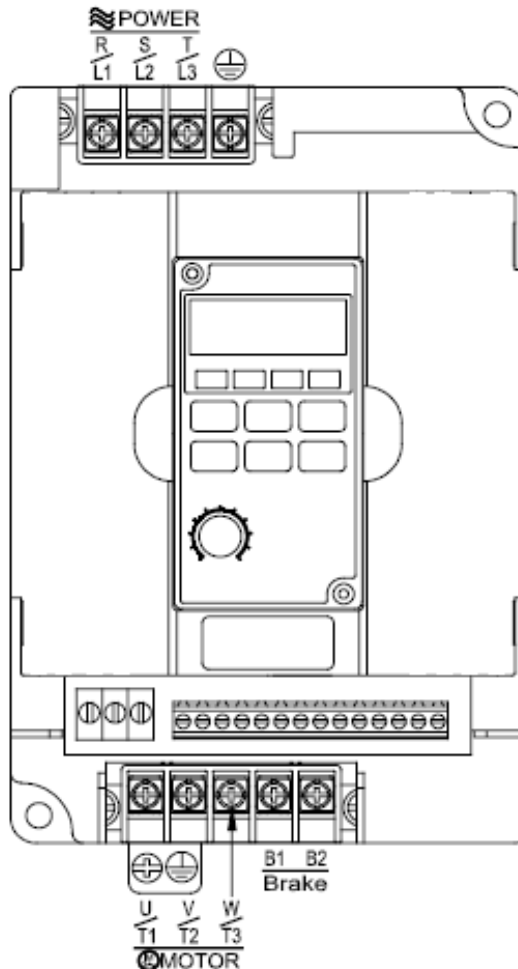



Table 3-1 Description of main circuit terminals of three-phase AC drive

Terminal	Name	Description
R, S, T	Three-phase power supply input terminals	Connect to the single-phase 220 VAC power supply.
B1, B2	Connecting terminals of braking resistor	Connect to the braking resistor for the AC drive of 2.2 kW and below (220 V) and 7.5 kW and below (other voltage classes).
U, V, W	AC drive output terminals	Connect to a three-phase motor.
	Grounding terminal	Must be grounded.

3.2.2 Wiring of AC Drive Main Circuit

■ Precautions on the Wiring

1) Power input terminals R, S, T

- The cable connection on the input side of the AC drive has no phase sequence requirement.
- The specification and installation method of external power cables must comply with the local safety regulations and related IEC standards.
- Use copper conductors of a proper size as power cables according to the recommended values in section 8.3.

2) Braking resistor connecting terminals B1 , B2

- The connecting terminals of the braking resistor are effective only for the AC configured with the built-in braking unit.
- The cable length of the braking resistor shall be less than 5 m. Otherwise, it may damage the AC drive.

3) AC drive output terminals U, V, W

- The specification and installation method of external power cables must comply with the local safety regulations and related IEC standards.
- Use copper conductors of a proper size as power cables according to the recommended values in section 8.3.
- The capacitor or surge absorber cannot be connected to the output side of the AC drive. Otherwise, it may cause frequent AC drive fault or even damage the AC drive.
- If the motor cable is too long, electrical resonance will be generated due to the impact of distributed capacitance. This will damage the motor insulation or generate higher leakage current, causing the AC drive to trip in overcurrent protection. If the motor cable is greater than 100 m long, an AC output reactor must be installed close to the AC drive.

4) Terminal  PE

- This terminal must be reliably connected to the main earthing conductor. Otherwise, it may cause electric shock, mal-function or even damage to the AC drive.
- Do not connect the earthing terminal to the neutral conductor of the power supply.
- The impedance of the PE conductor must be able to withstand the large shortcircuit current that may arise when a fault occurs.
- Select the size of the PE conductor according to the following table:

Cross-sectional Area of a Phase Conductor (S)	Min. Cross-sectional Area of Protective Conductor (Sp)
$S \leq 16 \text{ mm}^2$	S
$16 \text{ mm}^2 < S \leq 35 \text{ mm}^2$	16 mm ²
$35 \text{ mm}^2 < S$	S/2

– You must use a yellow/green cable as the PE conductor.

5) Requirements on upstream protection device

– Install upstream protection device on the input power circuit. The protection device must provide the protections on overcurrent, short-circuit and electrical isolation.

– When selecting the protective device, you should consider the current capacity of the power cable, system overload capacity and short-circuit capacity of the upstream power distribution of the equipment. Generally, make selection according to the recommended values in section 8.4.

3.2.3 Description of Control Circuit Terminals

■ Terminal Arrangement of Control Circuit

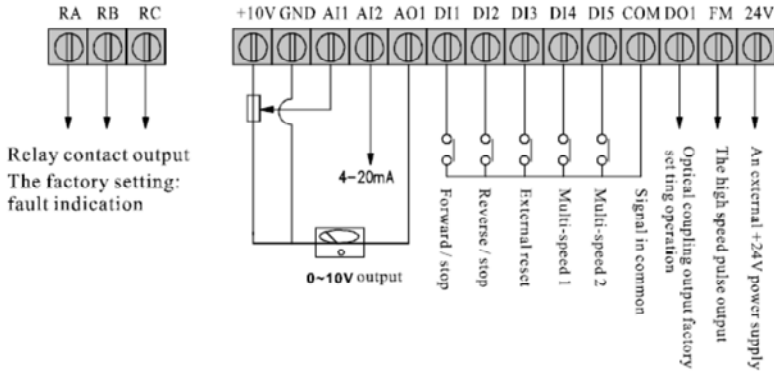

■ Description of Control Circuit Terminals

Table 3-3 Description of control circuit terminals

Type	Terminal	Name	Function Description
Power supply	+10V-GND	External +10 V power supply	Provide +10 V power supply to external unit. Generally, it provides power supply to external potentiometer with resistance range of 1–5 kΩ. Maximum output current: 10 mA
	+24V-COM	External +24V power supply	Provide +24 V power supply to external unit. Generally, it provides power supply to DI/DO terminals and external sensors. Maximum output current: 20 mA. Connect to +24 V by default.
Analog input	AI1-GND	Analog input 1	Input voltage range: 0–10 VDC Impedance: 22 kΩ
	AI2-GND	Analog input 2	Input range: 0–10 VDC/4–20 mA, decided by jumper J8 on the control board Impedance: 22kΩ (voltage input), 500 Ω (current input)
Digital input	DI1	Digital input 1	Optical coupling isolation, compatible with dual polarity input Impedance: 2.4 kΩ Voltage range for level input: 9–30 V
	DI2	Digital input 2	
	DI3	Digital input 3	
	DI4	Digital input 4	
	DI5	High-speed pulse input	Besides features of DI1–DI4 and DI6, it can be used for high-speed pulse input. Maximum input frequency: 100 kHz
Analog output	AO1-GND	Analog output 1	Voltage or current output is decided by jumper J5. Output voltage range: 0–10 V Output current range: 0–20 mA



Type	Terminal	Name	Function Description
Digital output	DO1-CME	Digital output 1	Optical coupling isolation, dual polarity open collector output Output voltage range: 0–24 V Output current range: 0–50 mA Note that CME and COM are internally insulated, but they are shorted by jumper externally. In this case DO1 is driven by +24 V by default. If you want to drive DO1 by external power supply, remove the jumper.
	FM- CME	High-speed pulse output	It is limited by P5-00 (FM terminal output mode selection). As high-speed pulse output, the maximum frequency hits 100 kHz. As open-collector output, its specification is the same as that of DO1
Relay output	T/A-T/B	NC terminal	Contact driving capacity: 250 VAC, 3 A, COS ϕ = 0.4 30 VDC, 1 A Applying to Overvoltage Category II circuit
	T/A-T/C	NO terminal	
	COM	Digital grounding	Please use twisted pair cable or screening wire

3.2.4 Wiring of AC Drive Control Circuit

Figure 3-3 Wiring mode of the AC drive control circuit

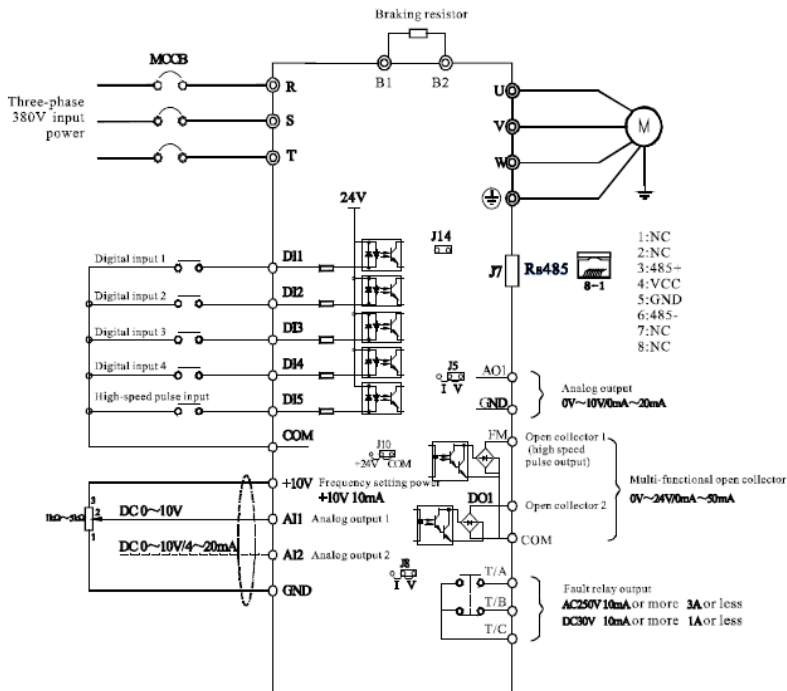

Diagram of three-phase inverter wiring

Note
<ul style="list-style-type: none"> All SSI700 series AC drives have the same wiring mode. The figure here shows the wiring of Three-phase 220~380 VAC drive. © indicates main circuit terminal, while ○ indicates control circuit terminal.



■ Description of Wiring of Signal Terminals

1) Wiring of AI terminals

Weak analog voltage signals are easy to suffer external interference, and therefore the shielded cable must be used and the cable length must be less than 20 m, as shown in following figure.

Figure 3-4 Wiring mode of AI terminals

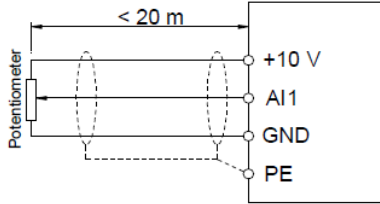

In applications where the analog signal suffers severe interference, install filter capacitor or ferrite magnetic core at the analog signal source.

Figure 3-5 Install filter capacitor or ferrite magnetic core

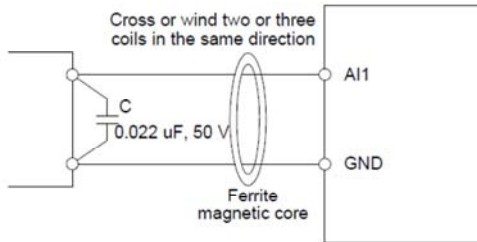

2) Wiring of DO terminal

When the digital output terminal needs to drive the relay, an absorption diode shall be installed between two sides of the relay coil. Otherwise, it may cause damage to the 24 VDC power supply. The driving capacity is not more than 50 mA.

Note
Do not reverse the polarity of the absorption diode during installation, as shown in Figure 3-3. Otherwise, the 24 VDC power supply will be damaged immediately once there is digital output.

Figure 3-6 DO terminal wiring diagram

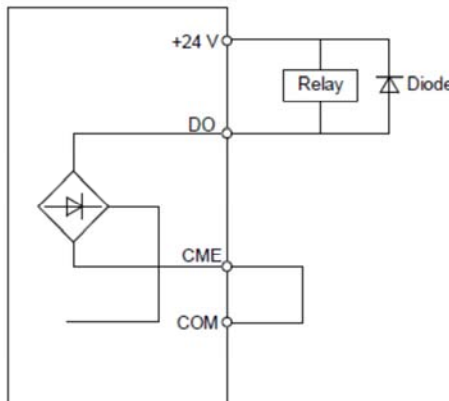



Operation, Display and Application Examples

Chapter 4 Operation, Display and Application Examples

4.1 Operation Panel

You can modify the parameters, monitor the working status and start or stop the SSI700 by operating the operation panel, as shown in the following figure.

Figure 4-1 Diagram of the operation panel

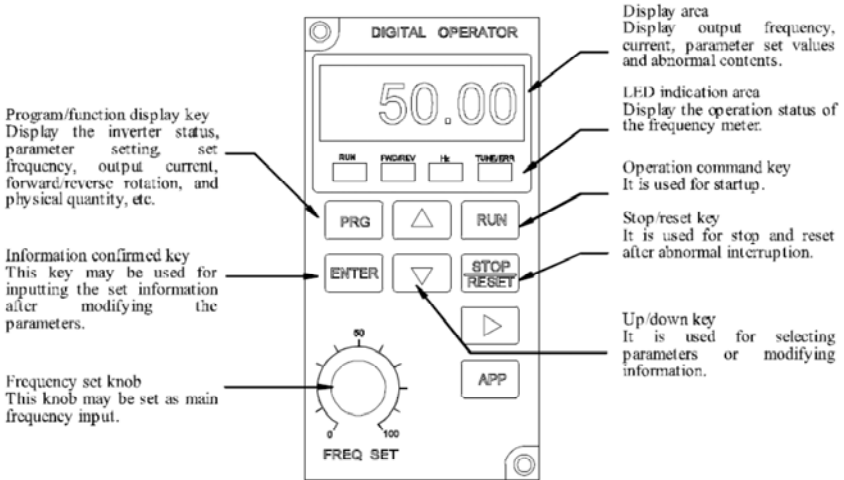

4.1.1 Description of Indicators

- RUN**

ON indicates that the AC drive is in the running state, and OFF indicates that the AC drive is in the stop state.

- LOCAL/REMOT**

It indicates whether the AC drive is operated by means of operation panel, terminals or communication.

LOCAL/REMOT: OFF	Operation panel control
LOCAL/REMOT: ON	Terminal control
LOCAL/REMOT: blinking	Communication control

- FWD/REV**

ON indicates reverse/REV rotation, and OFF indicates forward rotation.

- TUNE/TC**

When the indicator is ON, it indicates torque control mode. When the indicator is blinking slowly, it indicates the auto-tuning state. When the indicator is blinking quickly, it indicates the fault state.

- Unit Indicators**

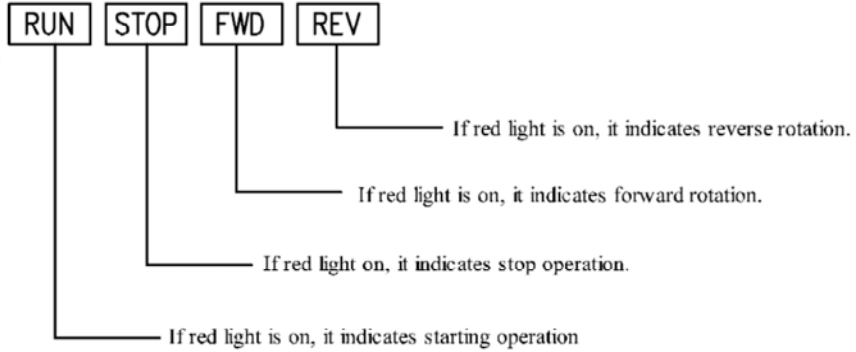

- Digital Display

The 5-digit LED display is able to display the set frequency, output frequency, monitoring data and fault codes.

4.1.2 Description of Keys on the Operation Panel

Table 4-1 Description of keys on the operation panel

Key	Name	Function
	Programming	Enter or exit Level I menu.
	Confirm	Enter the menu interfaces level by level, and confirm the parameter setting.
	Increment	Increase data or function code.
	Decrement	Decrease data or function code.
	Shift	Select the displayed parameters in turn in the stop or running state, and select the digit to be modified when modifying parameters.
	RUN	Start the AC drive in the operation panel control mode.
	Stop/Reset	Stop the AC drive when it is in the running state and perform the reset operation when it is in the fault state. The functions of this key are restricted in P7-02.
	Multifunction	Perform function switchover (such as quick switchover of command source or direction) according to the setting of P7-01.
	AI0	Potentiometer on the key pad

4.2 Viewing and Modifying Function Codes

The operation panel of the SSI700 adopts three-level menu.

The three-level menu consists of function code group (Level I), function code (Level II), and function code setting value (level III), as shown in the following figure.

Figure 4-2 Operation procedure on the operation panel

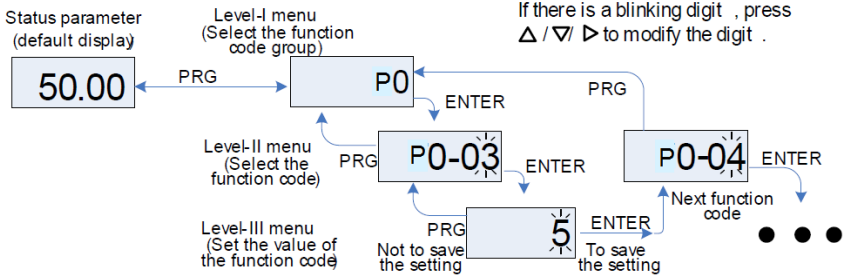

You can return to Level II menu from Level III menu by pressing **PRG** or **ENTER**.

- After you press **ENTER**, the system saves the parameter setting first, and then goes back to Level II menu and shifts to the next function code.
- After you press **PRG**, the system does not save the parameter setting, but directly returns to Level II menu and remains at the current function code.

Here is an example of changing the value of P3-02 to 15.00 Hz.

Figure 4-3 Example of changing the parameter value

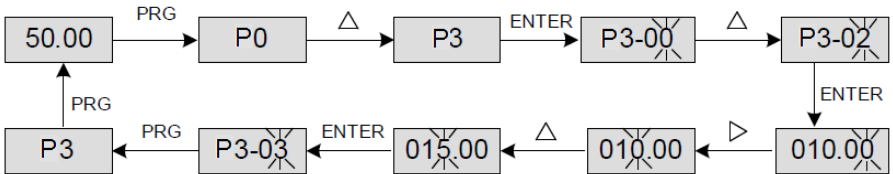

In Level III menu, if the parameter has no blinking digit, it means that the parameter cannot be modified. This may be because:

- Such a function code is only readable, such as, AC drive model, actually detected parameter and running record parameter.
- Such a function code cannot be modified in the running state and can only be changed at stop.

4.3 Definition and Operation of the Multifunction Key (APP)

You can define the function (command source switchover or rotation direction switchover) of the multifunction key in P7-01. For details, see the description of P7-01.

4.4 Viewing Status Parameters

In the stop or running state, you can press **▶** on the operation panel to display status parameters. Whether parameters are displayed is determined by the binary bits of values converted from the values of P7-03, P7-04, and P7-05 in the hexadecimal format.

In stop state, a total of 13 status parameters can be displayed, as listed in the following table.

Function Code	Parameter Name	Setting Range	Default
Group P7: Operation Panel and Display			
P7-05	LED display stop parameters	<p style="text-align: center;">0000–FFFF</p> <p style="text-align: center;"> 7 6 5 4 3 2 1 0 </p> <ul style="list-style-type: none"> — Set frequency (Hz) — Bus voltage (V) — DI input status — DO output status — AI1 voltage (V) — AI2 voltage (V) — AI3 voltage (V) — Count value <p style="text-align: center;"> 15 14 13 12 11 10 9 8 </p> <ul style="list-style-type: none"> — Length value — PLC stage — Load speed — PID setting — Pulse setting frequency (kHz) — Reserved — Reserved — Reserved <p>If a parameter needs to be displayed during the running, set the corresponding bit to 1, and set P7-05 to the hexadecimal equivalent of this binary number.</p>	0

In running state, five running status parameters are displayed by default, and you can set whether other parameters are displayed by setting P7-03 and P7-04, as listed in the following table.

Function Code	Parameter Name	Setting Range	Default
Group P7: Operation Panel and Display			
P7-03	LED display running parameters 1	<p>0000–FFFF</p>	1F
P7-04	LED display running parameters 2	<p>0000–FFFF</p> <p>If a parameter needs to be displayed during the running, set the corresponding bit to 1, and set P7-03 to the hexadecimal equivalent of this binary number.</p>	0

When the AC drive is powered on again after power failure, the parameters that are selected before power failure are displayed.

Select the required parameters by pressing . Set the values of the parameters by referring to the following example.

1. Determine the parameters to be displayed.

Running frequency, Bus voltage, Output voltage, Output current, Output frequency, Output torque, PID feedback, Encoder feedback speed

2. Set the binary data.

P7-03: 0000 0000 0111 1101B, P7-04: 0010 0000 0000 0001B

3. Convert the binary data to hexadecimal data:

P7-03: 007DH, P7-04: 2001H

The values displayed on the operation panel are respectively H.1043 and H.2001 respectively for P7-03 and P7-04.



4.5 Starting or Stopping the AC Drive

4.5.1 Selecting the Start/Stop Command Source

There are three start/stop command sources, namely, operation panel control, terminal control, and communication control. You can select the command source in P0-01.

Function Code	Parameter Name	Setting Range	Default	Property
Group P0: Standard Function Parameters				
P0-01	Command source selection Run/Stop	0: Operation panel control (LED off) 1: Terminal control (LED on) 2: Communication control (LED blinking)	0	☆

It is used to determine the input channel of the AC drive control commands, such as run, stop, forward rotation, reverse rotation and jog operation. You can input the commands in the following three channels:

- 0: Operation panel control ("LOCAL/REMOT" indicator off) Commands are given by pressing keys  and  on the operation panel.

- 1: Terminal control ("LOCAL/REMOT" indicator on)

Commands are given by means of multifunctional input terminals with functions such as FWD, REV, JOGF, and JOGR.

This control mode is applicable to scenarios where the DIP switch or electromagnetic button is used to start or stop the application system or scenarios where the dry contact signal is used to start or stop the AC drive.

The switch signal mode is set in P4-11. The input terminal of the start/stop signal is set in P4-00 to P4-09. For details, see the description of P4-11 and P4-00 to P4-09.

Example 1:

To use the DIP switch as the start/stop source, and allocate the forward rotation switch signal to DI2 and the reverse rotation switch signal to DI3, perform the setting as shown in the following figure.

Figure 4-6 Setting of using the DIP switch for start/stop

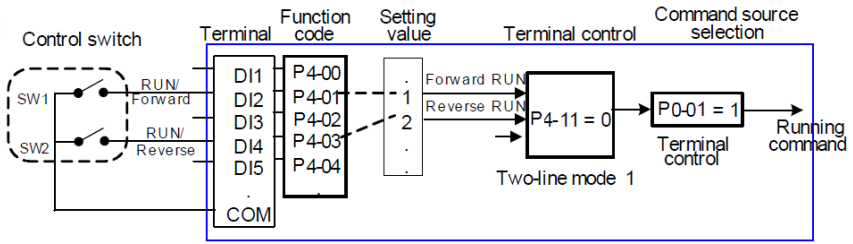

In the preceding figure, when SW1 is ON, the AC drive instructs forward rotation; when SW1 is OFF, the AC drive stops. When SW2 is ON, the AC drive instructs reverse running; when SW2 is OFF, the AC drive stops. If SW1 and SW2 are ON or OFF simultaneously, the AC drive stops.

Example 2:

To use the electromagnetic button as the start/stop source, and allocate the startup signal to DI2, stop signal to DI3 and reverse rotation signal to DI4, perform the setting as shown in the following figure.

Figure 4-7 Setting of using the electromagnetic button for start/stop

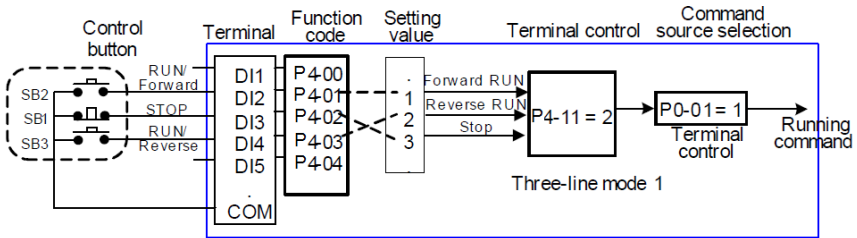

In the preceding figure, SB1 must stay ON during normal start and running. The AC drive stops immediately after SB1 becomes OFF. The signals from SB2 and SB3 become valid once they become ON. The running state of the AC drive is determined by the final actions on the three buttons.

2: Communication control

The most common configuration is when the host computer is used to control running of the AC drive by means of communication, such as the RS485. The SSI700 interacts with the user programmable also by means of communication.

Figure 4-8 Setting for start/stop using the communication control mode

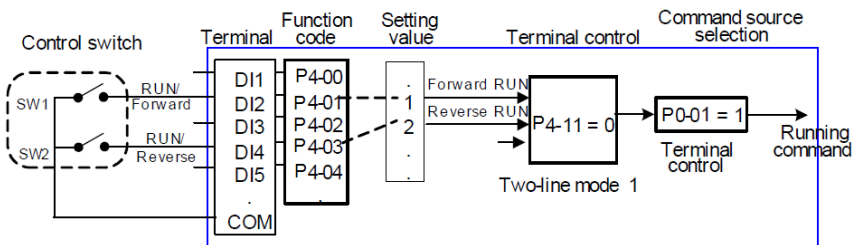

When 13-04 is set to a non-zero number, the function of automatic AC drive stop upon communication timeout is enabled. This prevents uncontrollable AC drive running due to faults of the communication cable or the host computer.

The communication port of the AC drive supports the Modbus-RTU protocol, and the communication is implemented only when the host computer supports the Modbus-RTU master station protocol.

4.5.2 Start Mode

The SSI700 supports three start modes, namely, direct start, rotational speed tracking restart, and pre-excited start (asynchronous motor), set in P6-00.

- P6-00 = 0 (direct start)

It is applicable to small-inertia load. The frequency curve in this mode is shown in the following figure.

DC braking before the start is applicable to drive of load such as elevator and crane. Startup frequency is applicable to drive with burst start under start torque, such as cement mixer.

Figure 4-9 Frequency curve of direct start

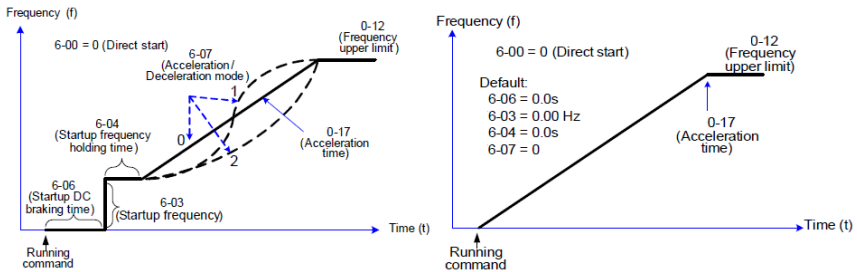

- P6-00 = 1 (Rotational speed tracking restart)

It is applicable to large-inertia load. The frequency curve in this mode is shown in the following figure. If the load motor is still rotating due to the inertia when the AC drive starts, this mode is used to prevent start overcurrent.

Figure 4-10 Frequency curve of rotational speed tracking restart

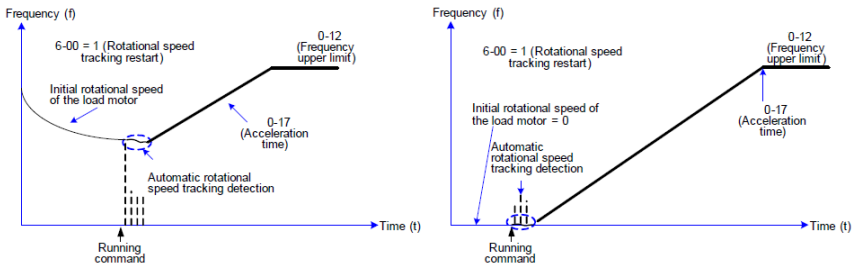

- P6-00 = 2 (Pre-excited start)

It is applicable only to inductive asynchronous motor. The AC drive performs preexcitation before start, improving quick response of the motor and meeting the requirements of short acceleration time. The frequency curve in this mode is shown in the following figure.

Figure 4-11 Frequency curve of pre-excited start

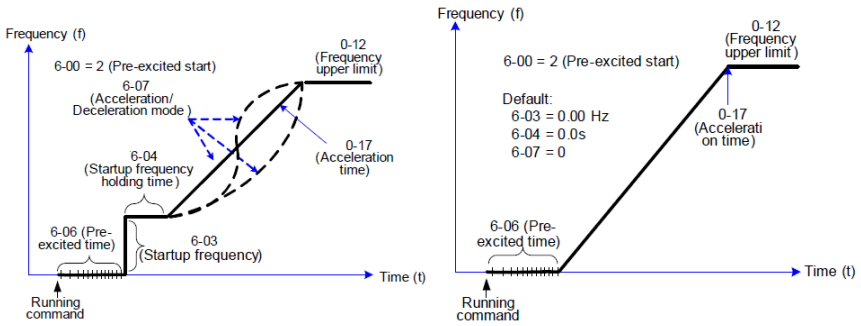

4.5.3 Stop Mode

The AC drive supports two stop modes, decelerate to stop and coast to stop, set in P6-10.

Figure 4-12 Diagram of two stop modes (decelerate to stop and coast to stop)

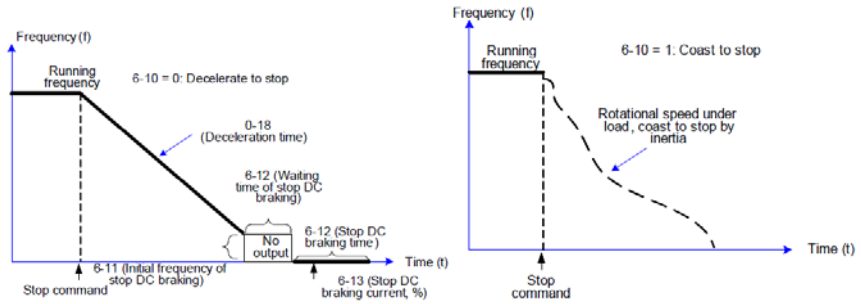

4.5.4 Timing Stop

The SSI700 supports timing stop. This function is enabled by P8-42 and the timing duration is determined by P8-43 and P8-44.

Figure 4-13 Setting of the timing stop function

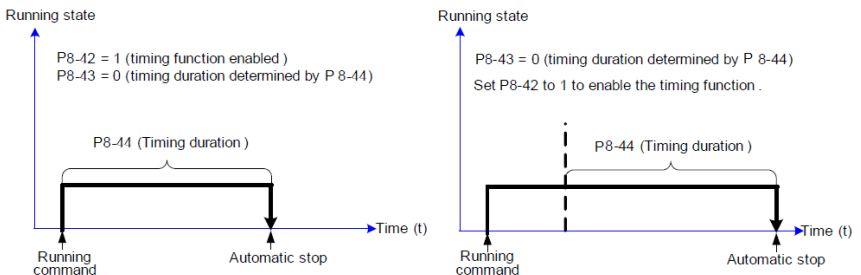

You can set the timing duration by means of analog input (such as potentiometer signal). For details, see the description of P8-43.

4.5.5 JOG Running

In certain applications, the AC drive needs to run in low speed temporarily to facilitate equipment test or other commissioning operations. In this case, you can set the AC drive to perform JOG running.

Figure 4-14 JOG running

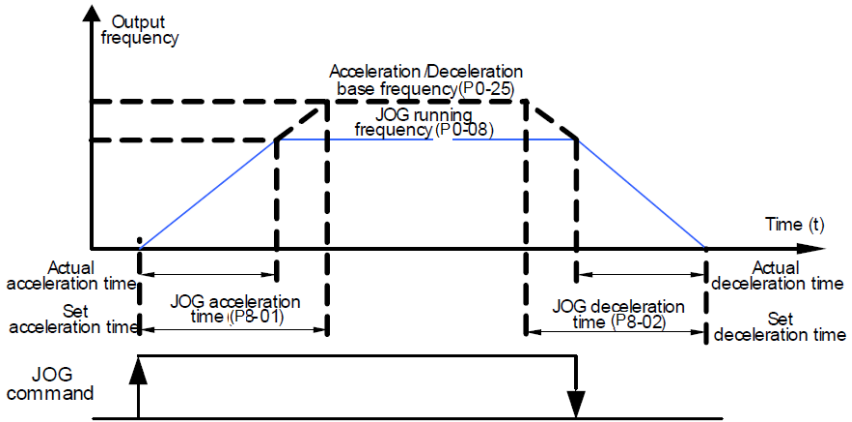

■ Parameter Setting and Operation of JOG Running in Operation Panel Control

Figure 4-15 JOG running in operation panel control

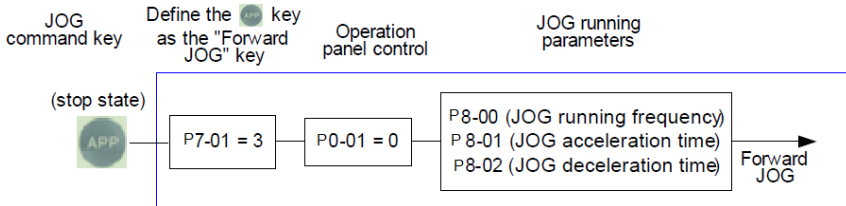

Set the parameters according to the preceding figure. In stop state of the AC drive, hold down **APP** and the AC drive starts JOG running. After you release **APP**, the AC drive decelerates to stop.

To perform reverse JOG, set P7-01 to 4 and P8-13 to 1. Hold down **APP** and the AC drive starts reverse JOG running.

■ Parameter Setting and Operation of JOG Running in DI Terminal Control

For equipment that requires frequent JOG operations, such as textile machine, it is more convenient to control JOG running by using keys or buttons. To achieve convenient control, perform the setting according to the following figure.

Figure 4-16 JOG running in DI terminal control

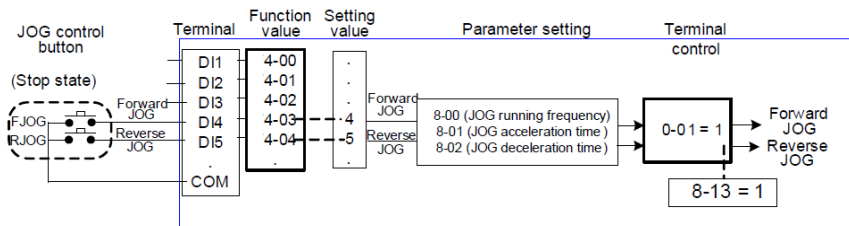



After performing the setting according to the preceding figure, press the FJOG button in stop state of the AC drive. Then, the AC drive starts forward JOG. After you press the FJOG button again, the AC drive decelerates to stop.

4.6 Setting the Running Frequency

The AC drive provides two frequency sources, namely, main frequency source A and auxiliary frequency source B. You can select one frequency source and switch over between the two sources. You can also perform superposition on the two sources by setting the calculation formula to meet different control requirements of different scenarios.

4.6.1 Frequency Setting by the Main Frequency Source

There are nine setting modes of main frequency sources, digital setting (UP/DOWN modification, non-retentive at power failure), digital setting (UP/DOWN modification, retentive at power failure), AI1, AI2, pulse setting, multi-reference, simple PLC, and communication setting. You can select one in P0-03.

Figure 4-17 Frequency set by the main frequency source

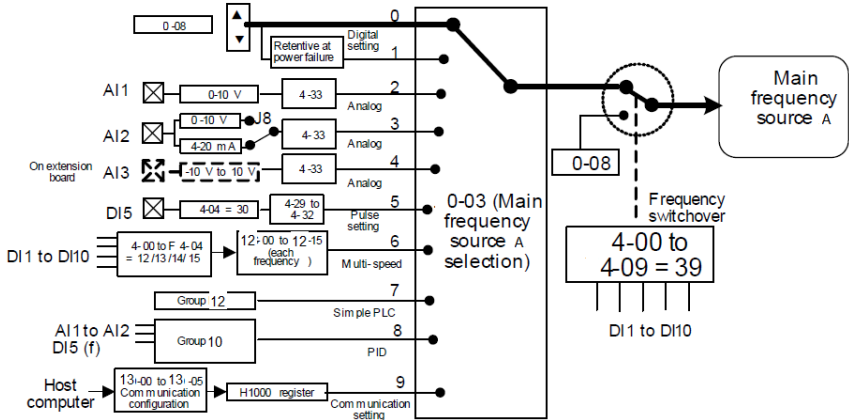

According to the preceding figure, the running frequency of the AC drive can be set by means of function codes, manual adjustment, analog input, multi-speed terminal, external feedback signal, internal PID regulator, or the host computer.

Set the corresponding function codes of each frequency setting mode, as shown in the preceding figure.

4.6.2 Frequency Setting by the Auxiliary Frequency Source

The frequency setting by the auxiliary frequency source is the same as the frequency setting by the main frequency source.

You can set the auxiliary frequency source in P0-04.

Figure 4-18 Frequency set by the auxiliary frequency source

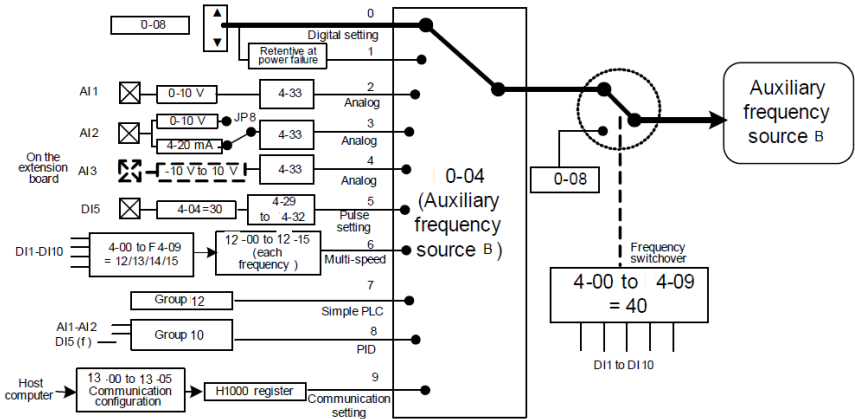

The relationship between the target running frequency and the main frequency source and auxiliary frequency source is set in P0-07, as follows:

- 1) Main frequency source A: The main frequency source is directly used to set the target running frequency.
- 2) Auxiliary frequency source B: The auxiliary frequency source is directly used to set the target running frequency.
- 3) A and B operation: There are four operation methods, namely, A+B, A-B, maximum of A and B, and minimum of A and B.
- 4) Frequency switchover: A DI terminal is used to switch over between the preceding three frequency setting channels.

The following figure shows how to set the relationship in P0-07, in which the bold line indicates the default setting.

Figure 4-19 Relationship between the target running frequency and main and auxiliary frequency sources

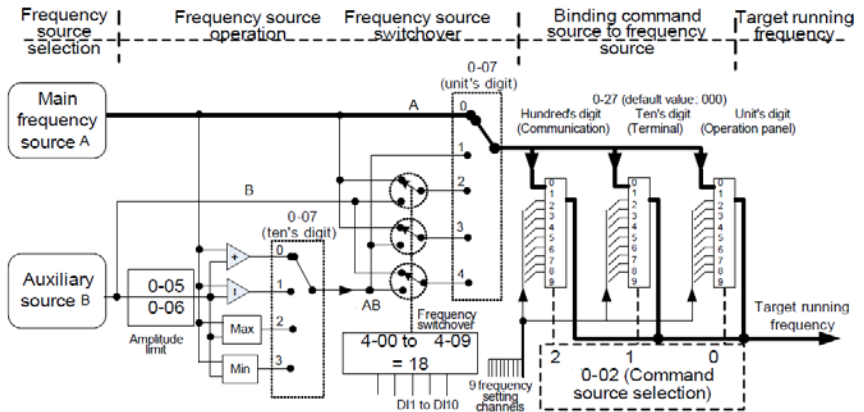

The operation between the main frequency source and the auxiliary frequency source can be used for closed-loop speed control. For example, using the main frequency source for setting the required frequency and the auxiliary frequency source for automatic adjustment, in conjunction with switchover performed by the external DI terminal signal, the required control can be implemented.



4.6.3 Binding Command Source to Frequency Source

The three command sources can be separately bound to frequency sources, as shown in Figure 4-19. When the specified command source (P0-01) is bound to a frequency source (corresponding digit in the value of P0-27), the frequency is determined by the frequency setting channel set in P0-27. In this case, both main and auxiliary frequency sources are ineffective.

4.6.4 AI as the Frequency Source

The AI terminal can be used as the frequency source. The SSI700 provides two AI terminals (AI1 and AI2) on the control board .

The following figures show how to use the AI as the frequency source.

Figure 4-20 Voltage input of AI1 connected to the potentiometer as the frequency source (2–10 V corresponding to 10–40 Hz)

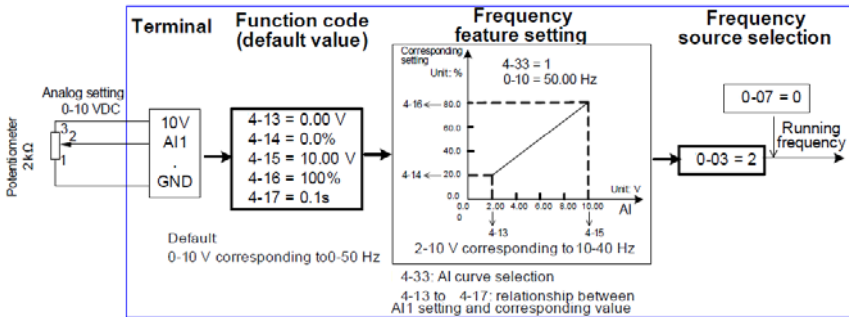
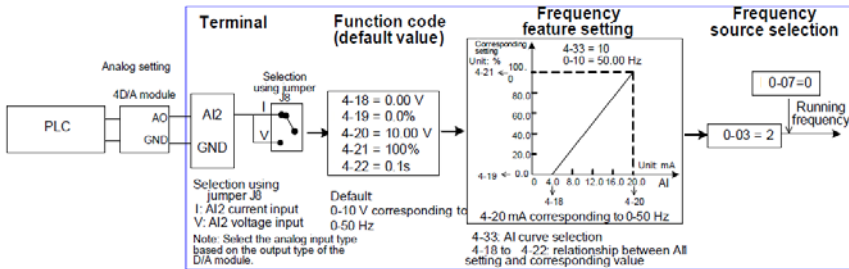

Figure 4-21 Current input of AI2 connected to 4DA module of the PLC as the frequency source (4–20 mA corresponding to 0–50 Hz)



- Notes**
1. AI1 provides 0–10 V voltage input. AI2 provides 0–10 V voltage input or 4–20 mA current input, determined by jumper J8 on the control board.
 2. When AI is used as the frequency source, 100% of the voltage or current input corresponding setting corresponds to the maximum frequency in P0-10.
 3. SSI700 provides five corresponding relationship curves, which can be selected in P4-33. The input values and corresponding settings of each curve are set in P4-13 to P4-27 .

4.6.5 Pulse Setting as the Frequency Source

In many scenarios, pulse input is used as the frequency source. The specifications of pulse signals are: voltage 9–30 V, frequency 0–100 kHz.

Only DI5 can be used for pulse input. The relationship between pulse input from DI5 and the corresponding setting is set in P4-28 to P4-31. The relationship is a two-point line, and

100% of pulse input corresponding setting corresponds to the maximum frequency of P0-10, as shown in Figure 4-22.

Figure 4-22 Pulse setting as the frequency source

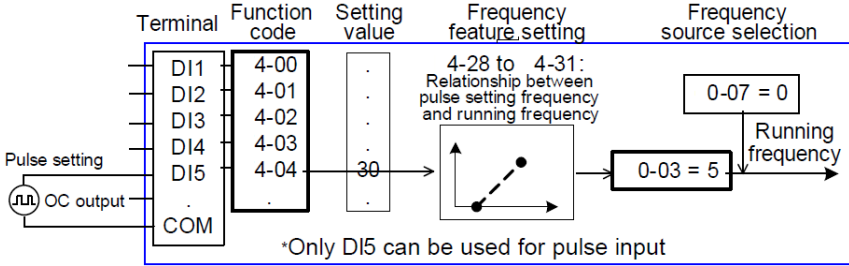

4.6.6 Frequency Closed-Loop Control

The SS700 has a built-in PID regulator. Together with the frequency sources, the PID regulator can implement automatic adjustment of progress control, such as constant temperature, constant pressure, and tension control.

Figure 4-23 Automatic adjustment by PID regulator

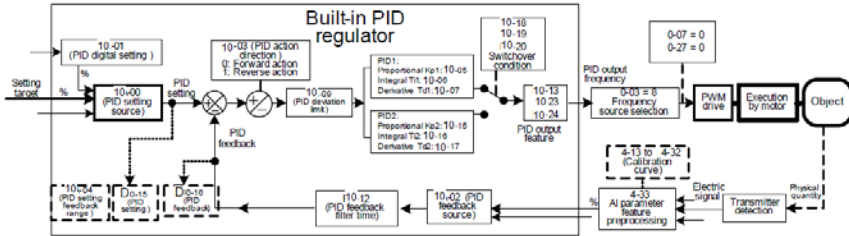

When PID frequency closed-loop control is implemented, P0-03 (Main frequency source A selection) must be set to 8 (PID). The PID-related parameters are set in group 10, as shown in Figure 4-23.

The SSI900 has two built-in equivalent PID calculating units. You can set the features, such as adjustment speed and accuracy, for the two units separately based on the actual conditions. Switchover between the two units can be implemented automatically or by means of an external DI terminal.

4.6.7 Multi-Speed Mode

In scenarios where the running frequency of the AC drive need not be adjusted continuously and only several frequencies are required, the multi-speed control can be used. The SSI700 supports a maximum of 16 running frequencies, which are implemented by state combinations of four DI terminals. Set the function codes corresponding to DI terminals to a value among 12 to 15, and then the DI terminals are specified as the multi-frequency input terminals. The multiple frequencies are set based on the multi-frequency table in group 12. In addition, you need to set P0-03 (Main frequency source A selection) to 6 (Multireference). The following figure shows how to set the multi-speed function.

Figure 4-24 Setting the multi-speed function

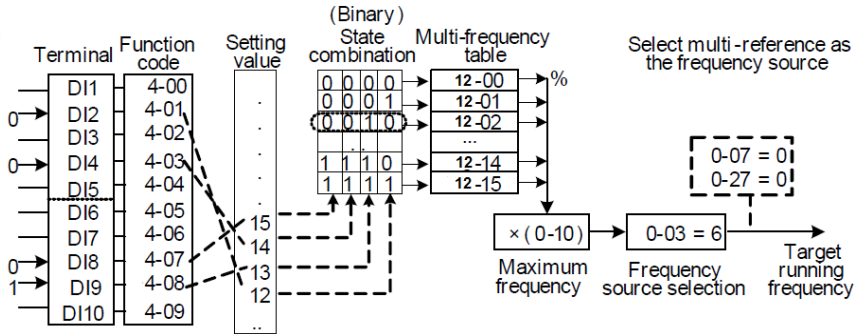

In the preceding figure, DI7, DI4, DI8, and DI2 are used as the multi-frequency input terminals, each of which has a bit value. The state combinations of these terminals correspond to multiple frequencies. When (DI7, DI4, DI8, DI2) = (0, 0, 1, 0), the state combination value is 2, corresponding to the value set in 12-02. The target running frequency is automatically calculated by 12-02 \times P0-10.

The SSI700 supports a maximum of four DI terminals to be used as the multi-frequency input terminals. You can also use less than four DI terminals, and the empty bit is considered to be 0.

4.6.8 Setting the Motor Rotating Direction

After the AC drive restores the default settings, press **RUN** to drive the motor to rotate. In this case, the rotating direction is regarded as the forward rotation. If the rotating direction is reverse to the direction required by the equipment, power off the AC drive and exchange any two of the output UVW cables (wait until the main capacitor of the AC drive is completely discharged).

In some applications where both forward rotation and reverse rotation are required, enable the reverse control (P8-13 = 0, default value) and meanwhile reverse the rotating direction by setting P0-09 to 1. Then press **RUN** to make the motor rotate in the reverse direction, as shown in the following figure.

Figure 4-25 Reversing the motor rotating direction

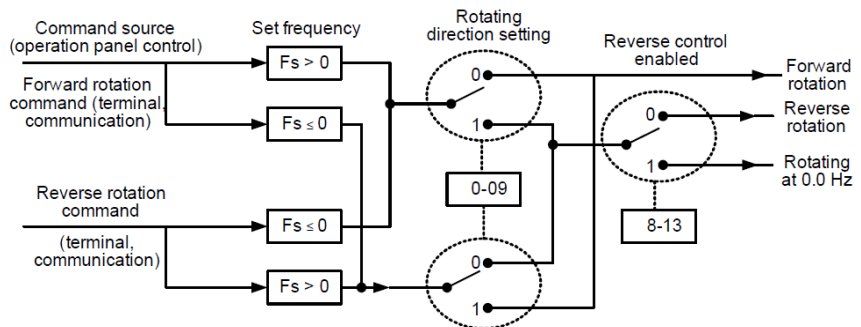

If the command source is terminal control and reverse rotation is required, use the default value 0 of P8-13 to enable reverse control.

According to the preceding figure, when the running frequency of the AC drive is set by means of communication (P0-03 = 9) and reverse control is enabled (P8-13 = 0), the AC drive instructs the reverse direction if the set frequency F_s is a negative value.

If the give running command is reverse rotation or the set frequency is a negative value, but reverse control is disabled (P8-13 = 1), the AC drive will run at 0 Hz and has no output.

In some applications where reverse rotation is prohibited, do not change the rotating direction by modifying the function codes because the function codes will be restored once the AC drive restores the default settings.

4.6.9 Setting the Fixed Length Control Mode

The SSI700 has the fixed length control function. The length pulses are sampled by the DI allocated with function 27 (Length count input). The "Actual length" (11-06) is obtained by dividing the number of pulses sampled by the value of 11-07 (Number of pulses per meter). If the actual length is larger than the "Set length" (11-05), the multifunctional DO terminal becomes ON.

In the process of fixed length control, the length can be reset by means of the DI terminal allocated with function 28 (Length reset). The related setting is shown in the following figure.

Figure 4-26 Function code setting for fixed length control

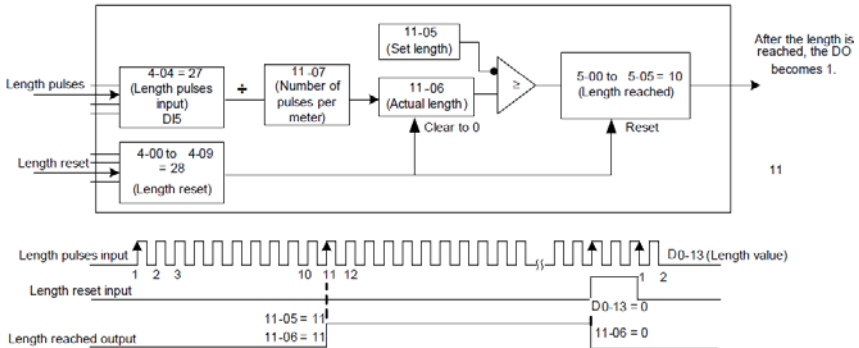

Notes

- In the fixed length control mode, the direction cannot be identified and only the length shall be calculated based on the number of pulses.
- Only DI5 can be allocated with the function "Length count input".
- An automatic stop system can be implemented if the length reached signal output by the DO is fed back to the AC drive input terminal with the stop function.

Figure 4-27 Common application example of the fixed length control function

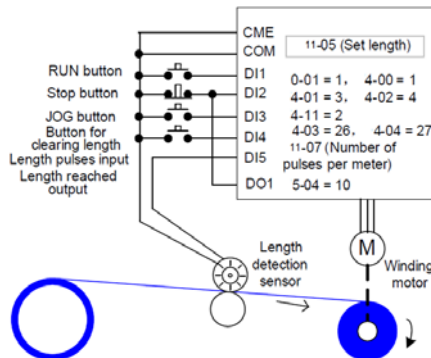



4.6.10 Use of the Counting Function

The count value needs to be collected by the DI terminal that is allocated with function 25. When the count value reaches 11-08 (Set count value), the DO terminal allocated with function 8 (Set count value reached) becomes ON. Then the counter stops counting.

When the count value reaches 11-09 (Designated count value), the DO terminal allocated with function 9 (Designated count value reached) becomes ON. The counter continues to count until "Set count value" is reached.

Figure 4-28 Parameter setting in the counting mode

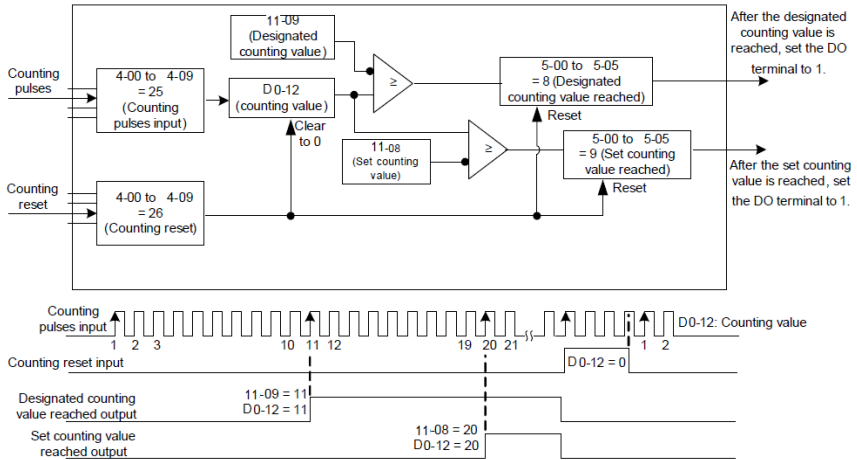

- | Notes | |
|-------|--|
| • | 11-09 (Designated count value) must not be greater than 11-08 (Set count value). |
| • | DI5 must be used when the pulse frequency is high. |
| • | The DO terminal that is allocated with function 9 (Designated count value reached) and the DO terminal that is allocated with function 8 (Set count value reached) must not be the same. |
| • | In the RUN/STOP state of the AC drive, the counter will not stop until "Set count value" is reached. |
| • | The count value is retentive at power failure. |
| • | An automatic stop system can be implemented if the signal output by the DO terminal with the function (Count value reached) is fed back to the DI terminal of the AC drive with stop function. |

4.7 Setting and Auto-tuning of Motor Parameters

4.7.1 Motor Parameters to Be Set

When the AC drive runs in the vector control mode (P0-00 = 0 or 1), accurate motor parameters are required to ensure desired driver performance and running efficiency. This is extremely different from the V/F control (P0-00 = 1).

Motor parameters (motor 1 by default) that need to be set are listed in the following table. Table 4-2 Motor parameters to be set

Parameter	Description	Remark
P1-00	Motor type	Asynchronous motor, variable frequency asynchronous motor,
P1-01 to P1-05	Rated motor power, Rated motor voltage, Rated motor current, Rated motor frequency, Rated motor rotational speed	Model parameters, manual input
P1-06 to P1-10	Motor internal equivalent stator resistance, inductive reactance and rotor inductance	Auto-tuning parameters

4.7.2 Motor Auto-tuning

To obtain the motor parameters, the AC drive can perform dynamic auto-tuning or static auto-tuning. For the asynchronous motor that cannot be disconnected from the load, you can input the motor parameters of the same model that was successfully auto-tuned before.

Auto-tuning	Application	Result
No-load dynamic auto-tuning	It is applied to applications where the motor (synchronous motor or asynchronous motor) can be disconnected from the load.	Best
With-load dynamic auto-tuning	It is applied to applications where the motor asynchronous cannot be disconnected from the load.	OK
Static auto-tuning	It is applied to applications where the motor (asynchronous motor only) cannot be disconnected from the load and dynamic auto-tuning is not allowed.	Poor
Manual input	It is applied to applications where the motor (asynchronous motor only) cannot be disconnected from the load. Input the motor parameters of the same model that was successfully autotuned before into function codes P1-00 to P1-10.	OK

The following motor auto-tuning description takes motor 1 as an example.

The process of motor auto-tuning is as follows:

- 1) If the motor can be disconnected from the load, disconnect the motor from the load mechanically after power-off so that the motor can run without load.
- 2) After power-on, set P0-01 (Command source selection) to 0 (Operation panel control).
- 3) Input the motor nameplate parameters (such as P1-00 to P1-05) correctly and input the following parameters based on the actually selected motor.

P1-00: Motor type selection
 P1-01: Rated motor power
 P1-02: Rated motor voltage
 P1-03: Rated motor current
 P1-04: Rated motor frequency
 P1-05: Rated motor rotational speed

For asynchronous motor, set P1-11 (Auto-tuning selection) to 2 (Asynchronous motor complete auto-tuning). Press  on the operation panel. The operation panel displays:



Then press  on the operation panel. The AC drive will drive the motor to accelerate/ decelerate and run in the forward/reverse direction, and the RUN indicator is ON. The autotuning lasts approximately 2 minutes. When the preceding display information

disappears and the operation panel returns to the normal parameter display status, it indicates that the auto-tuning is complete.

The AC drive will automatically calculate the following motor parameters:

P1-06: Stator resistance (asynchronous motor)

P1-07: Rotor resistance (asynchronous motor)

P1-08: Leakage inductive reactance (asynchronous motor)

P1-09: Mutual inductive reactance (asynchronous motor)

P1-10: No-load current (asynchronous motor)

If the motor cannot be disconnected from the load, set P1-11 (Auto-tuning selection) to 1

(Asynchronous motor static tuning) and then press  on the operation panel. The motor auto-tuning starts.

4.7.3 Setting and Switchover of Multiple Groups of Motor Parameters

You can select the current effective motor parameter group by means of function code P0-26 or DI terminals with functions 41 and 42. When the DI terminals with functions 41 and 42 become ON, they are privileged and the setting of P0-26 becomes invalid.

4.8 Use of DI Terminals

The control board provides five DI terminals DI1 to DI5.

The internal hardware of DI terminals are configured with 24 VDC power supply for detection. You can input a signal to a DI terminal of the AC drive only by shorting the DI terminal and COM.

By default, P4-38 = 0000 and P4-39 = 0000. When a DI terminal is shorted to COM, it is active (logic 1). When a DI terminal is not shorted to COM, it is inactive (logic 0).

You can change the DI terminal active mode. That is, a DI terminal is inactive (logic 0) when being shorted with COM, and active (logic 1) when being not shorted to COM. In this case, it is necessary to change the corresponding bit in P4-38 and P4-39 (these two parameters respectively specifying the active mode setting of DI1 to DI5 and DI16 to DI10) to 1.

The AC drive also provides P4-10 (DI filter time) for the DI signal to improve the antiinterference level. For DI1 to DI3, the AC drive provides the DI signal delay function, convenient for some applications requiring delay.

Figure 4-29 DI delay setting

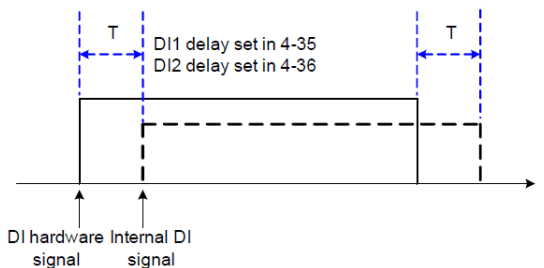

The preceding 5 DI terminals can be defined in function codes P4-00 to P4-04. Each DI can be allocated with their respective function from the 50 functions. For details, see descriptions of P4-00 to P4-04.

The hardware design allows only DI5 to receive high-speed pulse signal. If high-speed pulse count is required, use DI5.



4.9 Use of DO Terminals

The control board provides three DO terminals, namely FM, DO1 and TA/TB/TC. FM and DO1 are transistor outputs and can drive 24 VDC low-voltage circuit; TA/TB/TC is relay output, and can drive 250 VAC control circuit.

You can define the function of the DO terminals by setting P5-01 and P5-04 to indicate the running state and alarm information of the AC drive. There are a total of 40 functions. For details, see the descriptions of group P5.

Terminal	Corresponding Function Code	Output Feature Description
FM-CME	P5-06 when P5-00 = 0	Transistor, able to output high-speed pulses 10 Hz to 100 kHz; drive capacity: 24 VDC, 50 Ma
	P5-01 when P5-00 = 1	Transistor; drive capacity: 24 VDC, 50 Ma
TA-TB-TC	P5-02	Relay; drive capacity: 250 VAC, 3 A
DO1-CME	P5-04	Transistor; drive capacity: 24 VDC, 50 mA

When P5-00 = 0, the FM terminal is high-speed pulse output. The frequency of output pulses indicates the value of the internal running parameters. The greater the value is, the higher the output pulse frequency is. The 100% value corresponds to 100 kHz. The property of the indicated internal parameter is defined by P5-06.

4.10 Use of AI Terminals

The AC drive supports a total of three AI terminals, among which AI1 and AI2 are provided on the control board.

Terminal	Input Signal Characteristic
AI1-GND	It receives the signal of 0–10 VDC.
AI2-GND	If J8 is connected to the position with "V" mark, it receives the signal of 0–10 VDC. If J8 is connected to the position with "I" mark, it receives the signal of 4–20 mA.

As external voltage/current signal, AI is used for frequency source setting, torque setting, voltage setting at V/F separation, and PID setting or feedback. The corresponding relationship of the voltage or current and actual setting or feedback is defined by P4-13 to P4-27.

Figure 4-30 Defining corresponding relationship of the voltage or current and actual setting or feedback

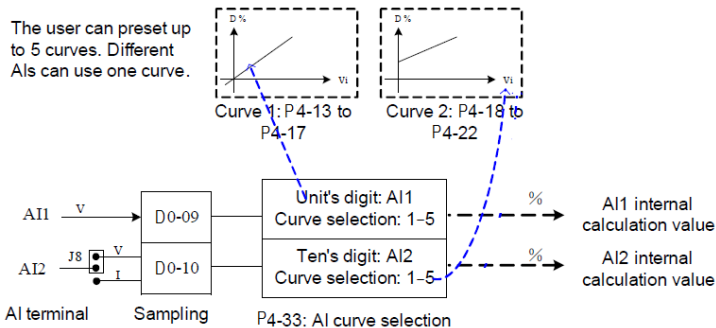

The sampling of AI terminals can be queried in D0-09 to D0-11. The calculation value is for internal subsequent calculation and cannot be directly read by the user.

4.11 Use of AO Terminals

The AC drive supports a total of two AO terminals, among which AO1 is provided by the control board.

Terminal	Input Signal Characteristic
A1-GND	It receives the signal of 0–10 VDC.
A12-GND	If J8 is connected to the position with "V" mark, it receives the signal of 0–10 VDC. If J8 is connected to the position with "I" mark, it receives the signal of 4–20 mA.

AO1 can be used to indicate the internal running parameters in the analog mode.

The property of indicated parameters can be defined by P5-07 and P5-08.

The designated running parameters can be rectified before output. The rectification feature is $Y = kX + b$, among which "X" indicates the running parameters to be output, and "k" and "b" of AO1 can be set by P5-10 and P5-11.

Figure 4-31 Setting of "k" and "b" of AO1

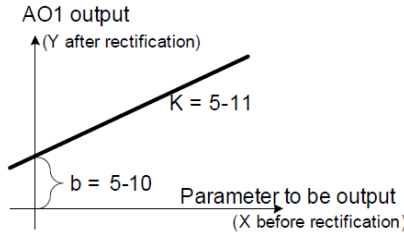

4.12 Use of Serial Communication

When communication mode RS485 on the SSI700 series AC drive, and set P0-28 correctly according to the used communication protocol type.

For the configuration of hardware communication parameters for the communication port, see group 13. Set the communication rate and data format to consistent with those of the host computer, which is the precondition of normal communication.

The SSI700 serial port itself supports the Modbus RTU slave communication protocol. You can query or modify the AC drive's function codes, query various running state parameters, and send running command and running frequency to the AC drive from the host computer through the serial port.

Figure 4-32 Communication control mode of the AC drive

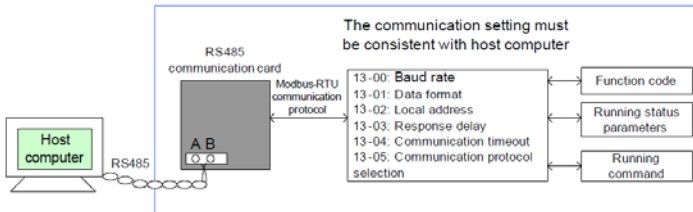

The SSI700 arranges the function codes, running state parameters and running commands in the "register parameter address" mode. The host computer can define the protocol of communication data interaction.

4.13 Password Setting

The AC drive provides the user password protection function. When 16-00 is set to a nonzero value, the value is the user password. The password takes effect after you after exit the function code editing state. When you press **PRG** again, "-----" will be displayed, and you must enter the correct user password to enter the menu.

To cancel the password protection function, enter with password and set 16-00 to 0.

4.14 Parameter Saving and Default Setting Restoring

22

After a function code is modified on the operation panel, the modification will be saved in the register of the AC drive and remain effective at next power-on.

The AC drive supports backup and restoration of parameter setting, which is convenient for commissioning.

The AC drive also provides the retentive function on alarm information and accumulative running time.

You can restore the backup values or default settings of the function codes of the AC drive or clear the running data through 16-01. For details, see the description of 16-01.

Figure 4-35 Parameter saving and default parameter restoring

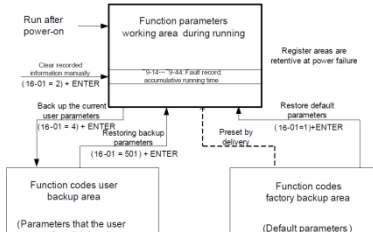



Function Code Table

Chapter 5 Function Code Table

If 16-00 is set to a non-zero number, parameter protection is enabled. You must enter the correct user password to enter the menu.

To cancel the password protection function, enter with password and set 16-00 to 0. Group P are standard function parameters.

The symbols in the function code table are described as follows:

"☆": The parameter can be modified when the AC drive is in either stop or running state.

"★": The parameter cannot be modified when the AC drive is in the running state.

"●": The parameter is the actually measured value and cannot be modified.

"*": The parameter is factory parameter and can be set only by the manufacturer.

5 Standard Function Parameters

Function Code	Parameter Name	Setting Range	Default	Property
Group P0: Standard Function Parameters				
P0-00	Motor control mode	0: Sensorless flux vector control (SFVC) 1: Voltage/Frequency (V/F) control	0	★
P0-01	Command source selection Run/Stop	0: Operation panel control (LED off) 1: Terminal control (LED on) 2: Communication control (LED blinking)	0	☆
P0-02	G/P(Motor) type display	1: G type(constant torque load)	1	*
P0-03	Main frequency source A selection	0: Digital setting Preset P0-08, UP/DOWN Can be modified. (non-retentive at power failure) 1: Digital setting Preset P0-08, UP/DOWN Can be modified. (retentive at power failure) 2: AI1 3: AI2 4: Reserved 5: Pulse setting (DI5) 6: Multi-reference 7: Simple PLC 8: PID 9: Communication setting 10: Potentiometer key pad	10	★
P0-04	Auxiliary frequency source B selection	The same as P0-03 (Main frequency source A selection)	1	★
P0-05	Range of auxiliary frequency B for A and B operation	0: Relative to maximum frequency 1: Relative to main frequency A	0	☆
P0-06	Range of auxiliary frequency B for A and B operation	0%–150%	100%	☆



Function Code	Parameter Name	Setting Range	Default	Property
Group P0: Standard Function Parameters				
P0-07	Frequency source selection	Unit's digit (Frequency source selection)	00	☆
		0: Main frequency source A 1: A and B operation (operation relationship determined by ten's digit) 2: Switchover between A and B 3: Switchover between A and "A and B operation" 4: Switchover between B and "A and B operation"		
		Ten's digit (A and B operation relationship)		
		0: A+B 1: A-B 2: Maximum 3: Minimum		
P0-08	Preset frequency	0.00 to maximum frequency (valid when frequency source is digital setting)	50.00 Hz	☆
P0-09	Rotation direction	0: Same direction 1: Reverse direction	0	☆
P0-10	Maximum frequency	Vector : 50.00–320.00 Hz V/F : 50.00–3200.00 Hz	50.00 Hz	★
P0-11	Source of frequency upper limit	0: Set by P0-12 1: AI1 2: AI2 3: Reserved 4: Pulse setting (DI5) 5: Communication setting	0	★
P0-12	Frequency upper limit	Frequency lower limit (P0-14) to maximum frequency (P0-10)	50.00 Hz	☆
P0-13	Frequency upper limit offset	0.00 Hz to maximum frequency (P0-10)	0.00 Hz	☆
P0-14	Frequency lower limit	0.00 Hz to frequency upper limit (P0-12)	0.00 Hz	☆
P0-15	Carrier frequency	0.5–16.0 kHz	Model dependent	☆
P0-16	Carrier frequency adjustment with temperature	0: No 1: Yes	1	☆
P0-17	Acceleration time 1	0.00–650.00s (P0-19 = 2) 0.0–6500.0s (P0-19 = 1) 0–65000s (P0-19 = 0)	Model dependent	☆
P0-18	Deceleration time 1	0.00–650.00s (P0-19 = 2) 0.0–6500.0s (P0-19 = 1) 0–65000s (P0-19 = 0)	Model dependent	☆
P0-19	Acceleration/Deceleration time unit	0: 1s 1: 0.1s 2: 0.01s	1	★
P0-20	reserved	--	0	--
P0-21	Frequency offset of auxiliary frequency source for A and B operation	0.00 Hz to maximum frequency (P0-10)	0.00 Hz	☆
P0-22	Frequency reference resolution	1: 0.1 Hz 2: 0.01 Hz	2	★

Function Code	Parameter Name	Setting Range	Default	Property
Group P0: Standard Function Parameters				
P0-23	Retentive of digital setting frequency upon power failure	0: Not retentive 1: Retentive	0	☆
P0-24	Acceleration/Deceleration time base frequency	0: Maximum frequency (P0-10) 1: Set frequency 2: 100 Hz	0	★
Function Code	Parameter Name	Setting Range	Default	Property
Group P1: Motor 1 Parameters				
P1-00	Motor type selection	0: Common asynchronous motor 1: Variable frequency motor	0	★
P1-01	Rated motor power	0.1–4.0 kW	Model Dependent	★
P1-02	Rated motor voltage	1–500 V	Model Dependent	★
P1-03	Rated motor current	0.01–655.35 A (AC drive power ≤55 kW)	Model Dependent	★
P1-04	Rated motor frequency	0.01 Hz to maximum frequency	Model Dependent	★
P1-05	Rated motor rotational speed	1–65535 RPM	Model Dependent	★
P1-06	Stator resistance (asynchronous motor)	0.001–65.535 Ω (AC drive power ≤ 55 kW)	Model dependent	★
P1-07	Rotor resistance (asynchronous motor)	0.001–65.535 Ω (AC drive power ≤ 55 kW)	Model Dependent	★
P1-08	Leakage inductive reactance (motor)	0.01–655.35 mH (AC drive power ≤ 55 kW)	Model Dependent	★
P1-09	Mutual inductive reactance (motor)	0.1–6553.5 mH (AC drive power ≤ 55 kW)	Model Dependent	★
P1-10	No-load current (asynchronous motor)	0.01 to P1-03 (AC drive power ≤ 55 kW)	Model Dependent	★
P1-11	Auto-tuning selection	0: No auto-tuning 1: Asynchronous motor static auto-tuning 2: Asynchronous motor complete auto-tuning	0	★
Function Code	Parameter Name	Setting Range	Default	Property
Group P2: Vector Control Parameters				
P2-00	Speed loop proportional gain 1	0–100	30	☆
P2-01	Speed loop integral time 1	0.01–10.00s	0.50s	☆
P2-02	Switchover frequency 1	0.00 to P2-05	5.00HZ	☆
P2-03	Speed loop proportional gain 2	0–100	20	☆
P2-04	Speed loop integral time 2	0.01–10.00s	1.00s	☆
P2-05	Switchover frequency 2	P2-02 to maximum output frequency	10.0HZ	☆
P2-06	Time constant of speed loop filter	0.000–0.100s	0.000s	☆
P2-07	Vector control slip gain	50%–200%	150%	☆
P2-08	Vector control overexcitation gain	0–200	64	☆
P2-09	Digital setting of torque upper limit in speed control mode	0.0%–200.0%	150%	☆

Function Code	Parameter Name	Setting Range	Default	Property
Group P2: Vector Control Parameters				
P2-10	Torque upper limit source in speed control mode	0: Function code P2-09 setting 1: AI1 2: AI2 3: reserved 4: Pulse setting (DI5) 5: Communication setting 6: MIN(AI1,AI2) 7: MAX(AI1,AI2) 1~7 full range corresponding to P2-09	0	☆
P2-13	Excitation adjustment proportional gain	0~60000	2000	☆
P2-14	Excitation adjustment integral gain	0~60000	1300	☆
P2-15	Torque adjustment proportional gain	0~60000	2000	☆
P2-16	Torque adjustment integral gain	0~60000	1300	☆
P2-17	Speed loop integral property	Unit's digit: integral separation 0: Disabled 1: Enabled	0	☆
Function Code	Parameter Name	Setting Range	Default	Property
Group P3: V/F Control Parameters				
P3-00	Cut-off frequency of torque boost	0.00 Hz to maximum output frequency	50.0HZ	★
P3-01	Torque boost	0.0% (fixed torque boost) 0.1%~30.0%	Model dependent	☆
P3-02	V/F curve setting	0: Linear V/F 1: Multi-point V/F 2: Square V/F 3: 1.2-power V/F 4: 1.4-power V/F 6: 1.6-power V/F 8: 1.8-power V/F	0	★
P3-03	Multi-point V/F frequency 1(F1)	0.00 Hz to P3-05	0.00 Hz	★
P3-04	Multi-point V/F voltage 1 (V1)	0.0%~100.0%	0.0%	★
P3-05	Multi-point V/F frequency 2(F2)	P3-03 to P3-07	0.00 Hz	★
P3-06	Multi-point V/F voltage 2 (V2)	0.0%~100.0%	0.0%	★
P3-07	Multi-point V/F frequency 3 (F3)	P3-05 to rated motor frequency (P1-04)	0.00 Hz	★
P3-08	Multi-point V/F voltage 3 (V3)	0.0%~100.0%	0.0%	★
P3-09	V/F slip compensation gain	0%~200.0%	0.0%	☆
P3-10	V/F over-excitation gain	0~200	64	☆
P3-11	V/F oscillation suppression gain	0~100	Model dependent	☆



Function Code	Parameter Name	Setting Range	Default	Property
Group P4: Input Terminals				
P4-00	DI1 function selection	0: No function	1	★
P4-01	DI2 function selection	1: Forward RUN (FWD)	2	★
P4-02	DI3 function selection	2: Reverse RUN (REV)	9	★
P4-03	DI4 function selection	3: Three-line control	12	★
P4-04	DI5 function selection	4: Forward JOG (FJOG)	13	★
P4-05	Reserved	5: Reverse JOG (RJOG)	-	-
P4-06	Reserved	6: Terminal UP	-	-
P4-07	Reserved	7: Terminal DOWN	-	-
P4-08	Reserved	8: Coast to stop 9: Fault reset (RESET) 10: RUN pause 11: Normally open (NO) input of external fault 12: Multi-reference terminal 1 13: Multi-reference terminal 2 14: Multi-reference terminal 3 15: Multi-reference terminal 4 16: Terminal 1 for acceleration/ deceleration time selection 1 17: Terminal 2 for acceleration/ deceleration time selection 2 18: Frequency source switchover 19: UP and DOWN setting clear (terminal, operation panel) 20: Command source switchover terminal 1 21: Acceleration/Deceleration prohibited 22: PID pause 23: PLC status reset 24: Swing Frequency pause 25: Counter input 26: Counter reset 27: Length count input 28: Length reset 29: Torque control prohibited 30: Pulse input (enabled only for DI5) 31: Reserved 32: Immediate DC braking 33: Normally closed (NC) input of external fault 34: Frequency modification forbidden 35: Reverse PID action direction 36: External STOP terminal 1 37: Command source switchover terminal 2 38: PID integral pause 39: Switchover between main frequency source A and preset frequency 40: Switchover between auxiliary frequency source B and preset frequency 41: reserved 42: reserved 43: PID parameter switchover 44: reserved	-	-



Function Code	Parameter Name	Setting Range	Default	Property
Group P4: Input Terminals				
P4-09	Reserved	45: reserved 46: Speed control/Torque control switchover 47: Emergency stop 48: External STOP terminal 2 49: Deceleration DC braking 50: Clear the current running time 51~59: Reserved	-	-
P4-10	DI filter time	0.000–1.000s	0.010s	☆
P4-11	Terminal command mode	0: Two-line mode 1 1: Two-line mode 2 2: Three-line mode 1 3: Three-line mode 2	1	★
P4-12	Terminal UP/DOWNrate	0.01–65.535 Hz/s	1.0 Hz/s	☆
P4-13	AI1curve minimum input	0.00 V to P4-15	0.00 V	☆
P4-14	Corresponding setting of AI curve 1 minimum input	-100.00%+100.0%	0.0%	☆
P4-15	AI1curve maximum input	P4-13 to 10.00 V	10.00V	☆
P4-16	Corresponding setting of AI1curve maximum input	-100.00%+100.0%	100.0 %	☆
P4-17	AI1 filter time	0.00–10.00s	0.10s	☆
P4-18	AI2 curve minimum input	0.00 V to P4-20	0.00 V	☆
P4-19	Corresponding setting of AI2 curve minimum input	-100.00%+100.0%	0.0%	☆
P4-20	AI2 curve maximum input	P4-18 to 10.00 V	10.00V	☆
P4-21	Corresponding setting of AI2 curve maximum input	-100.00%+100.0%	100.0 %	☆
P4-22	AI2 filter time	0.00–10.00s	0.10s	☆
P4-28	Pulse minimum input	0.00 kHz to P4-30	0.00 kHz	☆
P4-29	Corresponding setting of pulse minimum input	-100.00%–100.0%	0.0%	☆
P4-30	Pulse maximum input	P4-28 to 50.00 kHz	50.00 kHz	☆
P4-31	Corresponding setting of pulse maximum input	-100.00%+100.0%	100.0 %	☆
P4-32	Pulse filter time	0.00–10.00s	0.10s	☆
P4-33	AI curve selection	Unit's digit (AI1 curve selection)	321	☆
		Curve 1 (2 points, see P4-13 to P4-16)		
		Curve 2 (2 points, see P4-18 to P4-21)		
		Curve 3 (2 points, see P4-23 to P4-26)		
		Curve 4 Reserved Curve 5 Reserve		
Ten's digit (AI2 curve selection)	Curve1 to curve 5 (same as AI1)			



Function Code	Parameter Name	Setting Range	Default	Property
Group P4: Input Terminals				
P4-34	Setting for AI less than minimum input	Unit's digit (Setting for AI1 less than minimum input)	000	☆
		0: Minimum value 1: 0.0%		
		Ten's digit (Setting for AI2 less than minimum input)		
		0, 1 (same as AI1)		
P4-35	DI1 delay time	0.0–3600.0s	0.0s	★
P4-36	DI2 delay time	0.0–3600.0s	0.0s	★
P4-38	DI valid mode selection1	Unit's digit (DI1 valid mode)	00000	★
		0: High level valid 1: Low level valid		
		Ten's digit (DI2 valid mode)		
		0, 1 (same as DI1)		
		Hundred's digit (DI3 valid mode)		
		0, 1 (same as DI1)		
		Thousand's digit(DI4 valid mode)		
		0, 1 (same as DI1)		
		Ten thousand's digit(DI5 valid mode)		
		0, 1 (same as DI1)		
Function Code	Parameter Name	Setting Range	Default	Property
Group P5: Output Terminals				
P5-00	FM terminal output mode	0: Pulse output (FMP) 1: Switch signal output (FMR)	0	☆
P5-01	FMR function (open collector output terminal)	0: No output 1: AC drive running 2: Fault output (stop)	0	☆
P5-02	Relay function (T/A-T/B-T/C)	3: Frequency-level detection BRAKE control 1 output	2	☆
P5-03	Reserved	4: Frequency reached 5: Zero-speed running (no output at stop)	-	-
P5-04	DO1 function selection (open-collector output terminal)	6: Motor overload pre-warning	4	☆
		7: AC drive overload pre-warning		
		8: Set count value reached		
		9: Designated count value reached		
		10: Length reached		
		11: PLC cycle complete		
		12: Accumulative running time reached		
		13: Frequency limited		
		14: Torque limited		
		15: Ready for RUN		
		16: AI1 larger than AI2(AI1>AI2)		
		17: Frequency upper limit reached		
		18: Frequency lower limit reached (no output at stop)		
19: Undervoltage state output				
20: Communication setting				
21: Complete orientation				
22: Location close to				
23: Zero-speed running 2 (having output at stop)				



Function Code	Parameter Name	Setting Range	Default	Property
Group P5: Output Terminals				
P5-05	Reserved	24: Accumulative power-on time reached 25: Frequency level detection BRAKE control 2 output 26: Frequency 1 reached 27: Frequency 2 reached 28: Current 1 reached 29: Current 2 reached 30: Timing reached 31: AI1 input limit exceeded 32: Load becoming 0 (Drop in) 33: Reverse running 34: Zero current state 35: Module temperature reached 36: Software current limit exceeded 37: Frequency lower limit reached (having output at stop) 38: Alarm output 39: Motor overheat warning 40: Current running time reached	-	-
P5-06	FMP function selection	0: Running frequency 1: Set frequency 2: Output current 3: Output torque (absolute value) 4: Output power 5: Output voltage	0	☆
P5-07	AO1 function selection	6: Pulse input 7: AI1 8: AI2 9: Reserved 10: Length 11: Count value	0	☆
P5-08	Reserved	12: Communication setting 13: Motor rotational speed 14: Output current 15: Output voltage 16: Reserved	-	-
P5-09	Maximum FMP output frequency	0.01–100.00 kHz	50.00 kHz	☆
P5-10	AO1 offset coefficient	-100.0%–100.0%	0.0%	☆
P5-11	AO1 gain	-10.00–10.00	1.00	☆
P5-17	FMR output delay time	0.0–3600.0s	0.0s	☆
P5-18	Relay1 output delay time	0.0–3600.0s	0.0s	☆
P5-20	DO1 output delay time	0.0–3600.0s	0.0s	☆
P5-22	DO valid mode selection	Unit's digit (FMR valid mode)	00000	☆
		0: Positive logic 1: Negative logic		
		Ten's digit (Relay valid mode)		
		0, 1 (same as FMR)		
		Thousand's digit (DO1 valid mode)		
		0, 1 (same as FMR)		



Function Code	Parameter Name	Setting Range	Default	Property
Group P6: Start/Stop Control				
P6-00	Start mode	0: Direct start 1: Rotational speed tracking restart 2: Pre-excited start (asynchronous motor)	0	☆
P6-01	Startup frequency	0.00–10.00 Hz	0.00Hz	☆
P6-02	Rotational speed tracking mode	0: From frequency at stop 1: From zero speed 2: From maximum frequency	0	★
P6-03	Rotational speed tracking speed	1–100	20	☆
P6-04	Startup frequency holdingtime	0.0–100.0s	0.0s	★
P6-05	Startup DC braking current/Pre-excited current	0%–100%	0%	★
P6-06	Startup DC braking time/Pre-excited time	0.0–100.0s	0.0s	★
P6-07	Acceleration/Deceleration mode	0: Linear acceleration/ deceleration 1: S-curve acceleration/ deceleration A 2: S-curve acceleration/ deceleration B	0	★
P6-08	Time proportion of S-curve start segment	0.0% to (100.0% – P6-09)	30.0%	★
P6-09	Time proportion of S-curve end segment	0.0% to (100.0% – P6-08)	30.0%	★
P6-10	Stop mode	0: Decelerate to stop 1: Coast to stop	0	☆
P6-11	Initial frequency of stop DC braking	0.00 Hz to maximum frequency	0.00 Hz	☆
P6-12	Waiting time of stop DC braking	0.0–100.0s	0.0s	☆
P6-13	Stop DC braking current	0%–100%	0%	☆
P6-14	Stop DC braking time	0.0–100.0s	0.0s	☆
P6-15	Brake use ratio	0%–100%	100%	☆
Function Code	Parameter Name	Setting Range	Default	Property
Group P7: Operation Panel and Display				
P7-00	Reserved		0	
P7-01	APP Key function selection	0:APP key disabled 1: Switchover between operation panel control and remote command control (terminal or communication) 2: Switchover between forward rotation and reverse rotation 3: Forward JOG 4: Reverse JOG	0	★
P7-02	STOP/RESET key function	0: STOP/RESET key enabled only in operation panel control 1: STOP/RESET key enabled in any operation mode	1	☆

Function Code	Parameter Name	Setting Range	Default	Property
Group P7: Operation Panel and Display				
P7-03	LED display running parameters 1	0000-FFFF Bit00: Running frequency 1 (Hz) Bit01: Set frequency (Hz) Bit02: Bus voltage (V) Bit03: Output voltage (V) Bit04: Output current (A) Bit05: Output power (kW) Bit06: Output torque (%) Bit07: DI input status Bit08: DO output status Bit09: AI1 voltage (V) Bit10: AI2 voltage (V) Bit11: Reserved Bit12: Count value Bit13: Length value Bit14: Load speed display Bit15: PID setting	1F	
P7-04	LED display running parameters 2	0000-FFFF Bit00: PID feedback Bit01: PLC stage Bit02: Pulse setting frequency (kHz) Bit03: Running frequency 2 (Hz) Bit04: Remaining running time Bit05: AI1 voltage before correction (V) Bit06: AI2 voltage before correction (V) Bit07: Reserved Bit08: Linear speed Bit09: Current power-on time (Hour) Bit10: Current running time (Min) Bit11: Pulse setting frequency (Hz) Bit12: Communication setting value Bit13: Encoder feedback speed (Hz) Bit14: Main frequency A display (Hz) Bit15: Auxiliary frequency B display (Hz)	0	☆
P7-05	LED display stop parameters	0000-FFFF Bit00: Set frequency (Hz) Bit01: Bus voltage (V) Bit02: DI input status Bit03: DO output status Bit04: AI1 voltage (V) Bit05: AI2 voltage (V) Bit06: Reserved Bit07: Count value Bit08: Length value Bit09: PLC stage Bit10: Load speed Bit11: PID setting Bit12: Pulse setting frequency (kHz)	33	☆

Function Code	Parameter Name	Setting Range	Default	Property
Group P7: Operation Panel and Display				
P7-06	Load speed display coefficient	0.0001–6.5000	1.0000	☆
P7-07	Heatsink temperature of inverter module	0.0–100.0°C	--	●
P7-08	Temporary software version	--	--	●
P7-09	Accumulative running time	0–65535 h	--	●
P7-10	Product number	--	--	●
P7-11	Software version	--	--	●
P7-12	Number of decimal places for load speed display	0: 0 decimal place 1: 1 decimal place 2: 2 decimal places 3: 3 decimal places	1	☆
P7-13	Accumulative power-on time	0–65535 h	0 h	●
P7-14	Accumulative power consumption	0–65535 kWh	--	●
Function Code	Parameter Name	Setting Range	Default	Property
Group P8: Auxiliary Functions				
P8-00	JOG running frequency	0.00 Hz to maximum frequency	2.00 Hz	☆
P8-01	JOG acceleration time	0.0–6500.0s	20.0s	☆
P8-02	JOG deceleration time	0.0–6500.0s	20.0s	☆
P8-03	Acceleration time 2	0.0–6500.0s	Model dependent	☆
P8-04	Deceleration time 2	0.0–6500.0s	Model dependent	☆
P8-05	Acceleration time 3	0.0–6500.0s	Model dependent	☆
P8-06	Deceleration time 3	0.0–6500.0s	Model dependent	☆
P8-07	Acceleration time 4	0.0–6500.0s	Model dependent	☆
P8-08	Deceleration time 4	0.0–6500.0s	Model dependent	☆
P8-09	Jump frequency 1	0.00 Hz to maximum frequency	0.00Hz	☆
P8-10	Jump frequency 2	0.00 Hz to maximum frequency	0.00Hz	☆
P8-11	Frequency jump amplitude	0.00 Hz to maximum frequency	0.00Hz	☆
P8-12	Forward/Reverse rotation dead-zone time	0.0–3000.0s	0.0s	☆
P8-13	Reverse control	0: Enabled 1: Disabled	0	☆
P8-14	Running mode when set frequency lower than frequency lower limit	0: Run at frequency lower limit 1: Stop 2: Run at zero speed	0	☆
P8-15	Droop control	0.00–10.00 Hz	0.00Hz	☆
P8-16	Accumulative power-on time	threshold 0–65000	0h	☆
P8-17	Accumulative running time	threshold 0–65000	0h	☆
P8-18	Startup protection	0: No 1: Yes	0	☆
P8-19	Frequency detection value (BRAKE control 1)	0.00 Hz to maximum frequency	50.00 Hz	☆

Function Code	Parameter Name	Setting Range	Default	Property
Group P8: Auxiliary Functions				
P8-20	Frequency detection hysteresis (BRAKE control hysteresis 1)	0.0%–100.0% (BRAKE control hysteresis 1)	5.0%	☆
P8-21	Detection range of frequency reached	0.00–100% (maximum frequency)	0.0%	☆
P8-22	Jump frequency during acceleration/deceleration	0: Disabled 1: Enabled	0	☆
P8-23	reserved	-	-	-
P8-24	reserved	-	-	-
P8-28	Frequency detection value (BRAKE control 2)	0.00 Hz to maximum frequency	50.00 Hz	☆
P8-29	Frequency detection hysteresis (BRAKE control hysteresis 2)	0.0%–100.0% (BRAKE control hysteresis 2)	5.0%	☆
P8-30	Any frequency reaching detection value 1	0.00 Hz to maximum frequency	50.00 Hz	☆
P8-31	Any frequency reaching detection amplitude 1	0.0%–100.0% (maximum frequency)	0.0%	☆
P8-32	Any frequency reaching detection value 2	0.00 Hz to maximum frequency	50.00 Hz	☆
P8-33	Any frequency reaching detection amplitude 2	0.0%–100.0% (maximum frequency)	0.0%	☆
P8-34	Zero current detection level	0.0%–300.0% (rated motor current)	5.0%	☆
P8-35	Zero current detection delay time	0.00–600.00s	0.10s	☆
P8-36	Output overcurrent threshold	0.0% (no detection) 0.1%–300.0% (rated motor current)	200.0 %	☆
P8-37	Output overcurrent detection delay time	0.00–600.00s	0.00s	☆
P8-38	Any current reaching 1	0.0%–300.0% (rated motor current)	100.0 %	☆
P8-39	Any current reaching 1 amplitude	0.0%–300.0% (rated motor current)	0.0%	☆
P8-40	Any current reaching 2	0.0%–300.0% (rated motor current)	100.0 %	☆
P8-41	Any current reaching 2 amplitude	0.0%–300.0% (rated motor current)	0.0%	☆
P8-42	Timing function	0: Disabled 1: Enabled	0	☆
P8-43	Timing duration source	0: P8-44 1: AI1 2: AI2 3: Reserved (100%of analog input corresponds to the value of P8-44)	0	☆
P8-44	Timing duration	0.0–6500.0 min	0.0 min	☆
P8-45	AI1 input voltage lower limit	0.00 V to P8-46	3.10V	☆
P8-46	AI1 input voltage upper limit	P8-45 to 10.00 V	6.80 V	☆
P8-47	Module temperature threshold	0–100°C	75°C	☆
P8-48	Cooling fan control	0: Fan working during running 1: Fan working continuously	0	☆

Function Code	Parameter Name	Setting Range	Default	Property
Group P8: Auxiliary Functions				
P8-49	Wakeup frequency	Dormant frequency (P8-51) to maximum frequency (P0-10)	0.00Hz	☆
P8-50	Wakeup delay time	0.0–6500.0s	0.0s	☆
P8-51	Dormant(Sleeping) frequency	0.00 Hz to wakeup frequency (P8-49)	0.00Hz	☆
P8-52	Dormant(Sleeping) delay time	0.0–6500.0s	0.0s	☆
P8-53	Current running time reached	0.0–6500.0 min	0.0 min	☆
Function Code	Parameter Name	Setting Range	Default	Property
Group 9: Fault and Protection				
P9-00	Motor overload protection selection	0: Disabled 1: Enabled	1	☆
P9-01	Motor overload protection gain	0.20–10.00	1.00	☆
P9-02	Motor overload warning coefficient	50%–100%	80%	☆
P9-03	Overvoltage stall gain	0 (no stall overvoltage)–100	0	☆
P9-04	Overvoltage stall protective voltage	120%–150%	130%	☆
P9-05	Overcurrent stall gain	0–100	20	☆
P9-06	Overcurrent stall protective current	100%–200%	150%	☆
P9-07	Short-circuit to ground upon power-on	0: Disabled 1: Enabled	1	☆
P9-09	Fault auto reset times	0–20	0	☆
P9-10	DO action during fault auto reset	0: Not act 1: Act	0	☆
P9-11	Time interval of fault auto reset	0.1s–100.0s	1.0s	☆
P9-12	Input phase loss protection/ contactor energizing protection selection	Unit's digit: Input phase loss protection Ten's digit: Contactor energizing protection 0: Disabled 1: Enabled	11	☆
P9-13	Output phase loss protection selection	0: Disabled 1: Enabled	1	☆
P9-14	1st fault type	0: No fault 1: Module overheat 1(OH1) 2: Overcurrent during acceleration (OCA) 3: Overcurrent during deceleration (OCD) 4: Overcurrent (Normal) at constant speed (OCN) 5: Overvoltage during Acceleration (OUA) 6: Overvoltage during Deceleration (OUD) 7: Overvoltage (Normal) at constant speed (OUN) 8: Buffer resistance overload (UU) 9: Undervoltage (LU) 10: AC drive overload (OL2)	-	●

Function Code	Parameter Name	Setting Range	Default	Property
Group 9: Fault and Protection				
P9-15	2nd fault type	11: Motor overload (OL1) 12: EEPROM read-write fault(ED) 13: External equipment fault(EF) 14: Communication fault(CE) 15: Contactor fault(RL) 16: Current detection fault(CC) 17: Motor auto-tuning fault(ER) 18: No fault 19: Accumulative running time Reached(OT) 20: AC drive hardware fault(EH) 21: Short circuit to ground(GF) 22: Motor over-speed(OS) 23: Motor overheat(OH2) 24: PID feedback lost during Running(PD) 25: Accumulative power-on time Reached(UT) 26: Off Load(LL) 27: Too large speed deviation (DEV) 28: Power output phase loss(LF) 29: Initial position fault 30: Power output phase loss	-	●
P9-16	3rd (latest) fault type		-	●
P9-17	Frequency upon 3rd fault	-	-	●
P9-18	Current upon 3rd fault	-	-	●
P9-19	Bus voltage upon 3rd fault	-	-	●
P9-20	DI status upon 3rd fault	-	-	●
P9-21	Output terminal status upon 3rd fault	-	-	●
P9-22	AC drive status upon 3rd fault	-	-	●
P9-23	Power-on time upon 3rd fault	-	-	●
P9-24	Running time upon 3rd fault	-	-	●
P9-25	reserved	-	-	-
P9-26	reserved	-	-	-
P9-27	Frequency upon 2nd fault	-	-	●
P9-28	Current upon 2nd fault	-	-	●
P9-29	Bus voltage upon 2nd fault	-	-	●
P9-30	DI status upon 2nd fault	-	-	●
P9-31	Output terminal status upon 2nd fault	-	-	●
P9-32	AC drive status upon 2nd fault	-	-	●
P9-33	Power-on time upon 2nd fault	-	-	●
P9-34	Running time upon 2nd fault	-	-	●
P9-37	Frequency upon 2nd fault	-	-	●



Function Code	Parameter Name	Setting Range	Default	Property
Group 9: Fault and Protection				
P9-38	Current upon 1nd fault	-	-	●
P9-39	Bus voltage upon 1nd fault	-	-	●
P9-40	DI status upon 1nd fault	-	-	●
P9-41	Output terminal status upon 1nd fault	-	-	●
P9-42	AC drive status upon 1rd fault	-	-	●
P9-43	Power-on time upon 1rd fault	-	-	●
P9-44	Running time upon 1rd fault	-	-	●
P9-47	Fault protection action selection 1	Unit's digit (Motor overload, OL1)	00000	☆
		0: Coast to stop 1: Stop according to the stop mode 2: Continue to run		
		Ten's digit (Power input phase loss,)		
		Same as unit's digit		
		Hundred's digit (Power output phase loss, LF)		
		Same as unit's digit		
		Thousand's digit (External equipment fault, EF)		
		Same as unit's digit		
		Ten thousand's digit (Communication fault, CE)		
Same as unit's digit				
P9-48	Fault protection action selection 2	Ten's digit (EEPROM read-write fault, EP)	00000	☆
		0: Coast to stop 1: Stop according to the stop Mode		
		Ten thousand's digit (Accumulative running time reached)		
		Same as unit's digit in P9-47		
P9-49	Fault protection action selection 3	Hundred's digit (Accumulative power-on time reached,UT)	00000	☆
		Same as unit's digit in P9-47		
		Thousand's digit (Load becoming0)		
		0: Coast to stop 1: Stop according to the stop mode 2: Continue to run at 7% of rated motor frequency and resume to the set frequency if the load recovers		
		Ten thousand's digit (PID feedback lost during running, PD)		
		Same as unit's digit in P9-47		



Function Code	Parameter Name	Setting Range	Default	Property
Group 9: Fault and Protection				
P9-50	Fault protection action selection 4	Unit's digit (Too large speed deviation)	00000	☆
		Same as unit's digit in P9-47		
		Ten's digit (Motor over-speed)		
		Same as unit's digit in P9-47		
		Hundred's digit (Initial position fault)		
		Same as unit's digit in P9-47		
		Thousand's digit (Speed feedback fault)		
		Same as unit's digit in P9-47		
		Ten thousand's digit: Reserved		
P9-54	Frequency selection for continuing to run upon fault	0: Current running frequency 1: Set frequency 2: Frequency upper limit 3: Frequency lower limit 4: Backup frequency upon abnormality	0	☆
P9-55	Backup frequency upon abnormality	0.0%–100.0% (maximum frequency)	100.0%	☆
P9-59	Action selection at instantaneous power failure	0: Invalid 1: Decelerate 2: Decelerate to stop	0	☆
P9-60	Action pause judging voltage at instantaneous power failure	80.0%–100.0%	90.0%	☆
P9-61	Voltage rally judging time at instantaneous power failure	0.00–100.00s	0.50s	☆
P9-62	Action judging voltage at instantaneous power failure	60.0%–100.0% (standard bus voltage)	80.0%	☆
P9-63	Protection upon load becoming 0	0: Disabled 1: Enabled	0	☆
P9-64	Detection level of load becoming 0	0.0%–100.0% (rated motor current)	10.0%	☆
P9-65	Detection time of load becoming 0	0.0–60.0s	1.0s	☆

Function Code	Parameter Name	Setting Range	Default	Property
Group 10: Process Control PID Function				
10-00	PID setting source	0: 10-01 1: A11 2: A12 3: reserved 4: Pulse setting (DI5) 5: Communication setting 6: Multi-reference	0	☆
10-01	PID digital setting	0.0%–100.0%	50.0%	☆



Function Code	Parameter Name	Setting Range	Default	Property
Group 10: Process Control PID Function				
10-02	PID feedback source	0: AI1 1: AI2 2: reserved 3: AI1 – AI2 4: Pulse setting (DI5) 5: Communication setting 6: AI1 + AI2 7: MAX (AI1 , AI2) 8: MIN (AI1 , AI2)	0	☆
10-03	PID action direction	0: Forward action 1: Reverse action	0	☆
10-04	PID setting feedback range	0–65535	1000	☆
10-05	Proportional gain Kp1	0.0–100.0	20.0	☆
10-06	Integral time Ti1	0.01–10.00s	2.00s	☆
10-07	Differential time Td1	0.00–10.000	0.000s	☆
10-08	Cut-off frequency of PID reverse rotation	0.00 to maximum frequency	2.00 Hz	☆
10-09	PID deviation limit	0.0%–100.0%	0.0%	☆
10-10	PID differential limit	0.00%–100.00%	0.10%	☆
10-11	PID setting change time	0.00–650.00s	0.00s	☆
10-12	PID feedback filter time	0.00–60.00s	0.00s	☆
10-13	PID output filter time	0.00–60.00s	0.00s	☆
10-15	Proportional gain Kp2	0.0–100.0	20.0	☆
10-16	Integral time Ti2	0.0–100.0	20.0	☆
10-17	Differential time Td2	0.000–10.000s	0.000s	☆
10-18	PID parameter switchover condition	0: No switchover 1: Switchover via DI 2: Automatic switchover based on deviation	0	☆
10-19	PID parameter switchover deviation 1	0.0% to 10-20	20.0%	☆
10-20	PID parameter switchover deviation 2	10-19 to 100.0%	80.0%	☆
10-21	PID initial value	0.0%–100.0%	0.0%	☆
10-22	PID initial value holding time	0.00–650.00s	0.00s	☆
10-23	Maximum deviation between two PID outputs in forward direction	0.00%–100.00%	1.00%	☆
10-24	Maximum deviation between two PID outputs in reverse direction	0.00%–100.00%	1.00%	☆
10-25	PID integral property	Unit's digit (Integral separated)	00	☆
		0: Invalid 1: Valid		
		Ten's digit (Whether to stop integral operation when the output reaches the limit)		
		0: Continue integral operation 1: Stop integral operation		

Function Code	Parameter Name	Setting Range	Default	Property
Group 10: Process Control PID Function				
10-26	PID operation at stop	0: No PID operation at stop 1: PID operation at stop	0	☆
10-27	Detection time of PID feedback loss	0.0–20.0s	0.0s	☆
10-28	Detection value of PID feedback loss	0.0%: Not judging feedback loss 0.1%–100.0%	0.0%	☆
Function Code	Parameter Name	Setting Range	Default	Property
Group 11: Swing Frequency, Fixed Length and Count				
11-00	Swing frequency setting mode	0: Relative to the central frequency 1: Relative to the maximum frequency	0	☆
11-01	Swing frequency amplitude	0.0%–100.0%	0.0%	☆
11-02	Jump frequency amplitude	0.0%–50.0%	0.0%	☆
11-03	Swing frequency cycle	0.0–3000.0s	10.0s	☆
11-04	Triangular wave rising time coefficient	0.0%–100.0%	50.0%	☆
11-05	Set length	0–65535 m	1000m	☆
11-06	Actual length	0–65535 m	0 m	☆
11-07	Number of pulses per meter	0.1–6553.5	100.0	☆
11-08	Set count value	1–65535	1000	☆
11-09	Designated count value	1–65535	1000	☆
Function Code	Parameter Name	Setting Range	Default	Property
Group 12: Multi-Reference and Simple PLC Function				
12-00	Reference 0	-100.0%~100.0%	0.0%	☆
12-01	Reference 1	-100.0%~100.0%	0.0%	☆
12-02	Reference 2	-100.0%~100.0%	0.0%	☆
12-03	Reference 3	-100.0%~100.0%	0.0%	☆
12-04	Reference 4	-100.0%~100.0%	0.0%	☆
12-05	Reference 5	-100.0%~100.0%	0.0%	☆
12-06	Reference 6	-100.0%~100.0%	0.0%	☆
12-07	Reference 7	-100.0%~100.0%	0.0%	☆
12-08	Reference 8	-100.0%~100.0%	0.0%	☆
12-09	Reference 9	-100.0%~100.0%	0.0%	☆
12-10	Reference 10	-100.0%~100.0%	0.0%	☆
12-11	Reference 11	-100.0%~100.0%	0.0%	☆
12-12	Reference 12	-100.0%~100.0%	0.0%	☆
12-13	Reference 13	-100.0%~100.0%	0.0%	☆
12-14	Reference 14	-100.0%~100.0%	0.0%	☆
12-15	Reference 15	-100.0%~100.0%	0.0%	☆
12-16	Simple PLC running mode	0: Stop after the AC drive runs one cycle 1: Keep final values after the AC drive runs one cycle 2: Repeat after the AC drive runs one cycle	0	☆



Function Code	Parameter Name	Setting Range	Default	Property
Group 12: Multi-Reference and Simple PLC Function				
12-17	Simple PLC retentive selection	Unit's digit (Retentive upon power failure)	00	☆
		0: No 1: Yes		
		Ten's digit (Retentive upon stop)		
		0: No 1: Yes		
12-18	Running time of simple PLC reference 0	0.0–6553.5s (h)	0.0s(h)	☆
12-19	Acceleration/deceleration time of simple PLC reference 0	0–3	0	☆
12-20	Running time of simple PLC reference 1	0.0–6553.5s (h)	0.0s(h)	☆
12-21	Acceleration/deceleration time of simple PLC reference 1	0–3	0	☆
12-22	Running time of simple PLC reference 2	0.0–6553.5s (h)	0.0s(h)	☆
12-23	Acceleration/deceleration time of simple PLC reference 2	0–3	0	☆
12-24	Running time of simple PLC reference 3	0.0–6553.5s (h)	0.0s(h)	☆
12-25	Acceleration/deceleration time of simple PLC reference 3	0–3	0	☆
12-26	Running time of simple PLC reference 4	0.0–6553.5s (h)	0.0s(h)	☆
12-27	Acceleration/deceleration time of simple PLC reference 4	0–3	0	☆
12-28	Running time of simple PLC reference 5	0.0–6553.5s (h)	0.0s(h)	☆
12-29	Acceleration/deceleration time of simple PLC reference 5	0–3	0	☆
12-30	Running time of simple PLC reference 6	0.0–6553.5s (h)	0.0s(h)	☆
12-31	Acceleration/deceleration time of simple PLC reference 6	0–3	0	☆
12-32	Running time of simple PLC reference 7	0.0–6553.5s (h)	0.0s(h)	☆
12-33	Acceleration/deceleration time of simple PLC reference 7	0–3	0	☆
12-34	Running time of simple PLC reference 8	0.0–6553.5s (h)	0.0s(h)	☆
12-35	Acceleration/deceleration time of simple PLC reference 8	0–3	0	☆
12-36	Running time of simple PLC reference 9	0.0–6553.5s (h)	0.0s(h)	☆
12-37	Acceleration/deceleration time of simple PLC reference 9	0–3	0	☆
12-38	Running time of simple PLC reference 10	0.0–6553.5s (h)	0.0s(h)	☆



Function Code	Parameter Name	Setting Range	Default	Property
Group 12: Multi-Reference and Simple PLC Function				
12-39	Acceleration/deceleration time of simple PLC reference 10	0-3	0	☆
12-40	Running time of simple PLC reference 11	0.0-6553.5s (h)	0.0s(h)	☆
12-41	Acceleration/deceleration time of simple PLC reference 11	0-3	0	☆
12-42	Running time of simple PLC reference 12	0.0-6553.5s (h)	0.0s(h)	☆
12-43	Acceleration/deceleration time of simple PLC reference 12	0-3	0	☆
12-44	Running time of simple PLC reference 13	0.0-6553.5s (h)	0.0s(h)	☆
12-45	Acceleration/deceleration time of simple PLC reference 13	0-3	0	☆
12-46	Running time of simple PLC reference 14	0.0-6553.5s (h)	0.0s(h)	☆
12-47	Acceleration/deceleration time of simple PLC reference 14	0-3	0	☆
12-48	Running time of simple PLC reference 15	0.0-6553.5s (h)	0.0s(h)	☆
12-49	Acceleration/deceleration time of simple PLC reference 15	0-3	0	☆
12-50	Time unit of simple PLC running	0: s (second)1:h (hour)	0	☆
12-51	Reference 0 source	0: Set by 12-00 1: AI1 2: AI2 3: Reserved 4: Pulse setting 5: PID 6: Set by preset frequency (P0-08), modified via terminal UP/DOWN	0	☆
Function Code	Parameter Name	Setting Range	Default	Property
Group 13: Communication Parameters				
13-00	Data format	0: No check, data format <8,N,2> 1: Even parity check, data format <8,E,1> 2: Odd Parity check, data format <8,O,1> 3: No check, data format <8,N,1> Valid for Modbus	0	☆
13-01	Baud rate	0: 300 BPs 1: 600 BPs 2: 1200 BPs 3: 2400 BPs 4: 4800 BPs 5: 9600 BPs 6: 19200 BPs 7: 38400 BPs 8: 57600 BPs 9: 115200 BPs	6005	☆
13-02	Local address	0: Broadcast address 1~247	1	☆



Function Code	Parameter Name	Setting Range	Default	Property
Group 13: Communication Parameters				
13-03	Response delay	0–20 ms Valid for Modbus	2 ms	☆
13-04	Communication timeout	0.0s (invalid) 0.1–60.0s	0.0s	☆
13-05	Modbus protocol selection	Unit's digit: Modbus protocol 0: Non-standard Modbus protocol 1: Standard Modbus protocol	30	☆
13-06	Communication reading current resolution	0: 0.01A 1: 0.1A	0	☆
Function Code	Parameter Name	Setting Range	Default	Property
Group 16: Function Code Management				
16-00	User password	0–65535	0	☆
16-01	Restore default settings	0: No operation 01: Restore factory settings except motor parameters 02: Clear records 04: Restore user backup parameters 501: Back up current user parameters	0	★
Function Code	Parameter Name	Setting Range	Default	Property
Group 17: Torque Control and Restricting Parameters				
17-00	Speed/Torque control selection	0: Speed control 1: Torque control	0	★
17-01	Torque setting source in torque control	0: Digital setting (17-03) 1: AI1 2: AI2 3: Reserved 4: Pulse setting (DI5) 5: Communication setting 6: MIN (AI1, AI2) 7: MAX (AI1, AI2) Full range of values 1–7 corresponds to the digital setting of 17-03.	0	★
17-03	Torque digital setting in torque control	-200.0%–200.0%	150.0 %	☆
17-04	reserved	--	0	–
17-05	Forward maximum frequency in torque control	0.00 Hz to maximum frequency (P0-10)	50.00 Hz	☆
17-06	Reverse maximum frequency in torque control	0.00 Hz to maximum frequency (P0-10)	50.00 Hz	☆
17-07	Acceleration time in torque control	0.00–65000s	0.00s	☆
17-08	Deceleration time in torque control	0.00–65000s	0.00s	☆

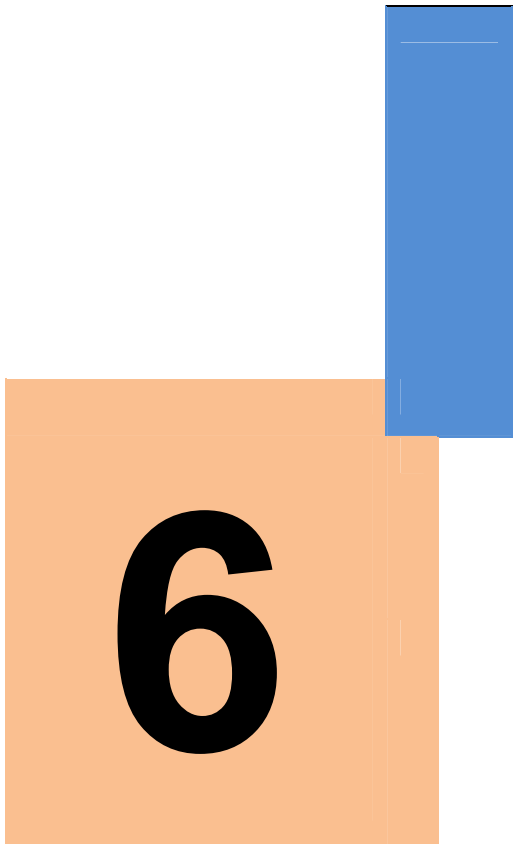

Description of Function Codes

Chapter 6 Description of Function Codes

Group P0: Basic Parameters

Function Code	Parameter Name	Setting Range	Default	Property
Group P0: Standard Function Parameters				
P0-00	Motor control mode	0: Sensorless flux vector control (SFVC) 1: Voltage/Frequency (V/F) control	0	★

- 0: Sensorless flux vector control (SFVC)

It indicates open-loop vector control, and is applicable to high-performance control applications such as machine tool, centrifuge, wire drawing machine and injection moulding machine. One AC drive can operate only one motor.



- 1: Voltage/Frequency (V/F) control

It is applicable to applications with low load requirements or applications where one AC drive operates multiple motors, such as fan and pump.

Notes				
• If vector control is used, motor auto-tuning must be performed because the advantages of vector control can only be utilized after correct motor parameters are obtained. Better performance can be achieved by adjusting speed regulator parameters in group P2 .				

Function Code	Parameter Name	Setting Range	Default	Property
Group P0: Standard Function Parameters				
P0-01	Command source selection Run/Stop	0: Operation panel control (LED off) 1: Terminal control (LED on) 2: Communication control (LED blinking)	0	☆

It is used to determine the input channel of the AC drive control commands, such as run, stop, forward rotation, reverse rotation and jog operation. You can input the commands in the following three channels:

- 0: Operation panel control ("LOCAL/REMOT" indicator off) Commands are given by pressing keys  and  on the operation panel.

- 1: Terminal control ("LOCAL/REMOT" indicator on)
Commands are given by means of multifunctional input terminals with functions such as FWD, REV, JOGF, and JOGR.

- 2: Communication control ("LOCAL/REMOT" indicator blinking) Commands are given from host computer. If this parameter is set to 2, a communication (Modbus RTU) must be installed.



Function Code	Parameter Name	Setting Range	Default	Property
Group P0: Standard Function Parameters				
P0-02	G/P(Motor) type display	1: G type(constant torque load)	Model dependent	*





Function Code	Parameter Name	Setting Range	Default	Property
Group P0: Standard Function Parameters				
P0-03	Main frequency source A selection	0: Digital setting Preset P0-08, UP/DOWN Can be modified. (non-retentive at power failure) 1: Digital setting Preset P0-08, UP/DOWN Can be modified. (retentive at power failure) 2: AI1 3: AI2 4: Reserved 5: Pulse setting (DI5) 6: Multi-reference 7: Simple PLC 8: PID 9: Communication setting 10: Potentiometer key pad	10	★

It is used to select the setting channel of the main frequency. You can set the main frequency in the following 10 channels:

- 0: Digital setting (non-retentive at power failure)

The initial value of the set frequency is the value of P0-08 (Preset frequency). You can change the set frequency by pressing  and  on the operation panel (or using the UP/DOWN function of input terminals). When the AC drive is powered on again after power failure, the set frequency reverts to the value of P0-08.

- 1: Digital setting (retentive at power failure)

The initial value of the set frequency is the value of P0-08 (Preset frequency). You can change the set frequency by pressing keys  and  on the operation panel (or using the UP/DOWN function of input terminals).

When the AC drive is powered on again after power failure, the set frequency is the value memorized at the moment of the last power failure.

Notes

that P0-23 (Retentive of digital setting frequency upon power failure) determines whether the set frequency is memorized or cleared when the AC drive stops. It is related to stop rather than power failure.

- 2: AI1 (0–10 V voltage input)
- 3: AI2 (0–10 V voltage or 4–20 mA current input, determined by jumper J8)

The frequency is set by analog input. The SSI700 control board provides two analog input (AI) terminals (AI1, AI2).

The SSI700 provides five curves indicating the mapping relationship between the input voltage of AI1, AI2 and the target frequency, three of which are linear (pointpoint) correspondence and two of which are four-point correspondence curves. You can set the curves by using function codes P4-13 to P4-27 and function codes in select curves for AI1, AI2.

When AI is used as the frequency setting source, the corresponding value 100% of the voltage/current input corresponds to the value of P0-10 (Maximum frequency).

- 5: Pulse setting (DI5)

The frequency is set by DI5 (high-speed pulse). The signal specification of pulse setting is 9–30 V (voltage range) and 0–100 kHz (frequency range). The corresponding value 100% of pulse setting corresponds to the value of P0-10 (Maximum frequency).



- 6: Multi-reference

In multi-reference mode, combinations of different DI terminal states correspond to different set frequencies. The SSI700 supports a maximum of 16 speeds implemented by 16 state combinations of four DI terminals (allocated with functions 12 to 15) in Group 12. The multiple references indicate percentages of the value of P0-10 (Maximum frequency). If a DI terminal is used for the multi-reference function, you need to perform related setting in group P4.

- 7: Simple PLC

When the simple programmable logic controller (PLC) mode is used as the frequency source, the running frequency of the AC drive can be switched over among the 16 frequency references. You can set the holding time and acceleration/deceleration time of the 16 frequency references. For details, refer to the descriptions of Group 12.

- 8: PID

The output of PID control is used as the running frequency. PID control is generally used in on-site control, such as constant pressure control and constant tension control.

When applying PID as the frequency source, you need to set parameters of PID function in group 10.

- 9: Communication setting

The frequency is set by means of communication.

If the AC drive is a slave in point-point communication and receives data as the frequency source, data transmitted by the master is used as the set frequency. The data format is -100.00% to 100.00%. 100% corresponds to the value of P0-10 (Maximum frequency). In other conditions, data is given by the host computer through the communication address 0x1000. The data format is -100.00% to 100.00%. 100.00% corresponds to the value of P0-10 (Maximum frequency). The SSI700 supports four host computer communication protocols: Modbus. They cannot be used simultaneously. If the communication mode is used.

- 10: Potentiometer key pad When AI is used as the frequency setting source, the corresponding value 100% of the voltage input corresponds to the value of P0-10 (Maximum frequency).



Function Code	Parameter Name	Setting Range	Default	Property
Group P0: Standard Function Parameters				
P0-04	Auxiliary frequency source B selection	0: Digital setting Preset P0-08, UP/DOWN Can be modified. (non-retentive at power failure) 1: Digital setting Preset P0-08, UP/DOWN Can be modified. (retentive at power failure) 2: AI1 3: AI2 4: Reserved 5: Pulse setting (DI5) 6: Multi-reference 7: Simple PLC 8: PID 9: Communication setting	1	★

When used as an independent frequency input channel (frequency source switched over from A to B), the auxiliary frequency source B is used in the same way as the main frequency source A (refer to P0-03).

When the auxiliary frequency source is used for operation (frequency source is "A and B operation"), pay attention to the following aspects:



1) If the auxiliary frequency source A is digital setting, the preset frequency (P0-08) does

not take effect. You can directly adjust the set main frequency by pressing keys  and  on the operation panel (or using the UP/DOWN function of input terminals).

2) If the auxiliary frequency source is analog input (AI1, AI2) or pulse setting, 100% of the input corresponds to the range of the auxiliary frequency B (set in P0-05 and P0-06).

3) If the auxiliary frequency source is pulse setting, it is similar to analog input.

Notes				
The main frequency source A and auxiliary frequency source B must not use the same channel. That is, P0-03 and P0-04 cannot be set to the same value.				

Function Code	Parameter Name	Setting Range	Default	Property
Group P0: Standard Function Parameters				
P0-05	Range of auxiliary frequency B for A and B operation	0: Relative to maximum frequency 1: Relative to main frequency A	0	☆
P0-06	Range of auxiliary frequency B for A and B operation	0%–150%	100%	☆

If A and B operation is used, P0-05 and P0-06 are used to set the adjustment range of the auxiliary frequency source.

You can set the auxiliary frequency to be relative to either maximum frequency or main frequency A. If relative to main frequency A, the setting range of the auxiliary frequency B varies according to the main frequency A.

Function Code	Parameter Name	Setting Range	Default	Property
Group P0: Standard Function Parameters				
P0-07	Frequency source selection	Unit's digit (Frequency source selection)	00	☆
		0: Main frequency source A 1: A and B operation (operation relationship determined by ten's digit) 2: Switchover between A and B 3: Switchover between A and "A and B operation" 4: Switchover between B and "A and B operation"		
		Ten's digit (A and B operation relationship)		
		0: A+B 1: A-B 2: Maximum 3: Minimum		

It is used to select the frequency setting channel. If the frequency source involves A and B operation, you can set the frequency offset in P0-21 for superposition to the A and B operation result, flexibly satisfying various requirements.

Figure 6-1 Frequency setting based on main frequency source A and auxiliary frequency source B

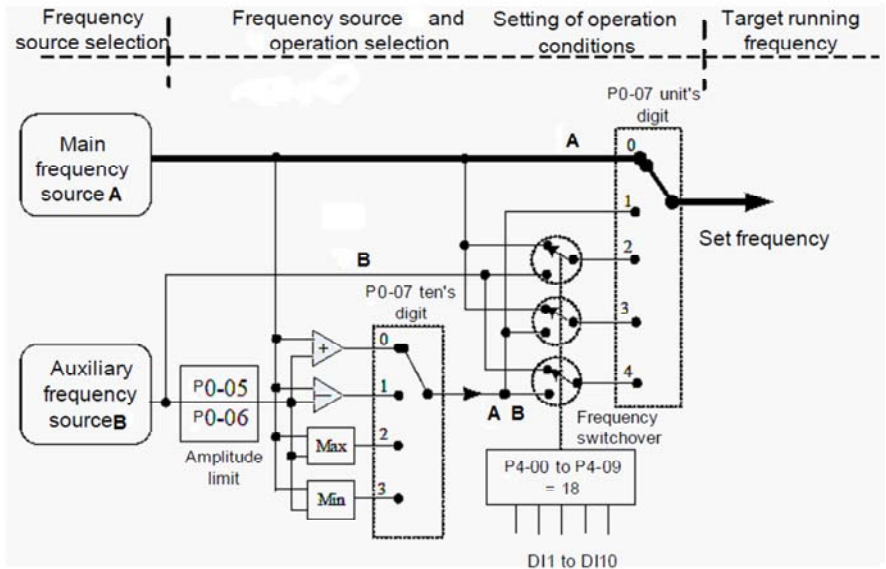

Function Code	Parameter Name	Setting Range	Default	Property
Group P0: Standard Function Parameters				
P0-08	Preset frequency	0.00 to maximum frequency (valid when frequency source is digital setting)	50.00 Hz	☆

If the frequency source is digital setting or terminal UP/DOWN, the value of this parameter is the initial frequency of the AC drive (digital setting).

Function Code	Parameter Name	Setting Range	Default	Property
Group P0: Standard Function Parameters				
P0-09	Rotation direction	0: Same direction 1: Reverse direction	0	☆

You can change the rotation direction of the motor just by modifying this parameter without changing the motor wiring. Modifying this parameter is equivalent to exchanging any two of the motor's U, V, W wires.

Notes

The motor will resume running in the original direction after parameter initialization. Do not use this function in applications where changing the rotating direction of the motor is prohibited after system commissioning is complete.

Function Code	Parameter Name	Setting Range	Default	Property
Group P0: Standard Function Parameters				
P0-10	Maximum frequency	Vector : 50.00–320.00 Hz V/F : 50.00–3200.00 Hz	50.00 Hz	★

When the frequency source is AI, pulse setting (DI5), or multi-reference, 100% of the input corresponds to the value of this parameter.

The output frequency of the SSI700 can reach up to 3200 Hz. To take both frequency reference resolution and frequency input range into consideration, you can set the number of decimal places for frequency reference in P0-22.



- If P0-22 is set to 1, the frequency reference resolution is 0.1 Hz. In this case, the setting range of P0-10 is 50.0 to 3200.0 Hz.
- If 0-22 is set to 2, the frequency reference resolution is 0.01 Hz. In this case, the setting range of P0-10 is 50.00 to 320.00 Hz.

Notes				
After the value of P0-22 is modified, the frequency resolution of all frequency related function codes change accordingly.				

Function Code	Parameter Name	Setting Range	Default	Property
Group P0: Standard Function Parameters				
P0-11	Source of frequency upper limit	0: Set by P0-12 1: AI1 2: AI2 3: Reserved 4: Pulse setting (DI5) 5: Communication setting	0	★

It is used to set the source of the frequency upper limit, including digital setting (P0-12), AI, pulse setting or communication setting. If the frequency upper limit is set by means of AI1, AI2, DI5 or communication, the setting is similar to that of the main frequency source A. For details, see the description of P0-03.

For example, to avoid runaway in torque control mode in winding application, you can set the frequency upper limit by means of analog input. When the AC drive reaches the upper limit, it will continue to run at this speed.

Function Code	Parameter Name	Setting Range	Default	Property
Group P0: Standard Function Parameters				
P0-12	Frequency upper limit	Frequency lower limit (P0-14) to maximum frequency (P0-10)	50.00 Hz	☆

This parameter is used to set the frequency upper limit.

Function Code	Parameter Name	Setting Range	Default	Property
Group P0: Standard Function Parameters				
P0-13	Frequency upper limit offset	0.00 Hz to maximum frequency (P0-10)	0.00 Hz	☆

If the source of the frequency upper limit is analog input or pulse setting, the final frequency upper limit is obtained by adding the offset in this parameter to the frequency upper limit set in P0-11.

Function Code	Parameter Name	Setting Range	Default	Property
Group P0: Standard Function Parameters				
P0-14	Frequency lower limit	0.00 Hz to frequency upper limit (P0-12)	0.00 Hz	☆

If the frequency reference is lower than the value of this parameter, the AC drive can stop, run at the frequency lower limit, or run at zero speed, determined by P8-14.

Function Code	Parameter Name	Setting Range	Default	Property
Group P0: Standard Function Parameters				
P0-15	Carrier frequency	0.5–16.0 kHz	Model dependent	☆

It is used to adjust the carrier frequency of the AC drive, helping to reduce the motor noise, avoiding the resonance of the mechanical system, and reducing the leakage current to the earth and interference generated by the AC drive.



If the carrier frequency is low, output current has high harmonics, and the power loss and temperature rise of the motor increase.

If the carrier frequency is high, power loss and temperature rise of the motor declines. However, the AC drive has an increase in power loss, temperature rise and interference.

Adjusting the carrier frequency will exert influences on the aspects listed in the following table.

Table 6-1 Influences of carrier frequency adjustment

Carrier frequency	Low	High
Motor noise	Large	Small
Output current waveform	Bad	Good
Motor temperature rise	High	Low
AC drive temperature rise	Low	High
Leakage current	Small	Large
External radiation interference	Small	Large

The factory setting of carrier frequency varies with the AC drive power. If you need to modify the carrier frequency, note that if the set carrier frequency is higher than factory setting, it will lead to an increase in temperature rise of the AC drive's heatsink. In this case, you need to de-rate the AC drive. Otherwise, the AC drive may overheat and alarm.

Function Code	Parameter Name	Setting Range	Default	Property
Group P0: Standard Function Parameters				
P0-16	Carrier frequency adjustment with temperature	0: No 1: Yes	1	☆

It is used to set whether the carrier frequency is adjusted based on the temperature. The AC drive automatically reduces the carrier frequency when detecting that the heatsink temperature is high. The AC drive resumes the carrier frequency to the set value when the heatsink temperature becomes normal. This function reduces the overheat alarms.

Function Code	Parameter Name	Setting Range	Default	Property
Group P0: Standard Function Parameters				
P0-17	Acceleration time 1	0.00–650.00s (P0-19 = 2) 0.0–6500.0s (P0-19 = 1) 0–65000s (P0-19 = 0)	Model dependent	☆
P0-18	Deceleration time 1	0.00–650.00s (P0-19 = 2) 0.0–6500.0s (P0-19 = 1) 0–65000s (P0-19 = 0)	Model dependent	☆

Acceleration time indicates the time required by the AC drive to accelerate from 0 Hz to "Acceleration/Deceleration base frequency" (P0-24), that is, t1 in Figure 6-2.

Deceleration time indicates the time required by the AC drive to decelerate from "Acceleration/Deceleration base frequency" (P0-24) to 0 Hz, that is, t2 in Figure 6-2.

Figure 6-2 Acceleration/Deceleration time

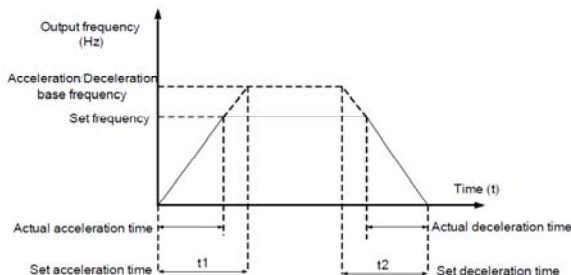

The SSI700 provides totally four groups of acceleration/deceleration time for selection.

You can perform switchover by using a DI terminal.

- Group 1: P0-17, P0-18
- Group 2: P8-03, P8-04
- Group 3: P8-05, P8-06
- Group 4: P8-07, P8-08

Function Code	Parameter Name	Setting Range	Default	Property
Group P0: Standard Function Parameters				
P0-19	Acceleration/Deceleration time unit	0:1s 1: 0.1s 2: 0.01s	1	★

To satisfy requirements of different applications, the SSI700 provides three acceleration/deceleration time units, 1s, 0.1s and 0.01s.

Notes				
Modifying this parameter will make the displayed decimal places change and corresponding acceleration/deceleration time also change.				

Function Code	Parameter Name	Setting Range	Default	Property
Group P0: Standard Function Parameters				
P0-21	Frequency offset of auxiliary frequency source for A and B operation	0.00 Hz to maximum frequency(P0-10)	0.00 Hz	☆

This parameter is valid only when the frequency source is set to "A and B operation". The final frequency is obtained by adding the frequency offset set in this parameter to the A and B operation result.

Function Code	Parameter Name	Setting Range	Default	Property
Group P0: Standard Function Parameters				
P0-22	Frequency reference resolution	1: 0.1 Hz 2: 0.01 Hz	2	★



It is used to set the resolution of all frequency-related parameters.



If the resolution is 0.1 Hz, the SSI700 can output up to 3200 Hz. If the resolution is 0.01 Hz, the SSI700 can output up to 600.00 Hz.

Notes				
<ul style="list-style-type: none"> • Modifying this parameter will make the decimal places of all frequency-related parameters change and corresponding frequency values change. • This parameter is not resumed when factory setting is resumed. 				

Function Code	Parameter Name	Setting Range	Default	Property
Group P0: Standard Function Parameters				
P0-23	Retentive of digital setting frequency upon power failure	0: Not retentive 1: Retentive	0	☆

This parameter is valid only when the frequency source is digital setting.

If P0-23 is set to 0, the digital setting frequency value resumes to the value of P0-08 (Preset frequency) after the AC drive stops. The modification by using keys  and  or the terminal UP/DOWN function is cleared.

If P0-23 is set to 1, the digital setting frequency value is the set frequency at the moment when the AC drive stops. The modification by using keys  and  or the terminal UP/DOWN function remains effective.

Function Code	Parameter Name	Setting Range	Default	Property
Group P0: Standard Function Parameters				
P0-24	Acceleration/Deceleration time base frequency	0: Maximum frequency (P0-10) 1: Set frequency 2: 100 Hz	0	★

The acceleration/deceleration time indicates the time for the AC drive to increase from 0 Hz to the frequency set in P0-24. If this parameter is set to 1, the acceleration/deceleration time is related to the set frequency. If the set frequency changes frequently, the motor's acceleration/deceleration also changes.

Group P1: Motor Parameters

Function Code	Parameter Name	Setting Range	Default	Property
Group P1: Motor 1 Parameters				
P1-00	Motor type selection	0: Common asynchronous motor 1: Variable frequency asynchronous motor	0	★
P1-01	Rated motor power	0.1–5.5kW	Model Dependent	★
P1-02	Rated motor voltage	1–500 V	Model Dependent	★
P1-03	Rated motor current	0.01–655.35 A (AC drive power ≤55 kW)	Model Dependent	★
P1-04	Rated motor frequency	0.01 Hz to maximum frequency	Model Dependent	★
P1-05	Rated motor rotational speed	1–65535 RPM	Model Dependent	★

Set the parameters according to the motor nameplate no matter whether V/F control or vector control is adopted.

To achieve better V/F or vector control performance, motor auto-tuning is required. The motor auto-tuning accuracy depends on the correct setting of motor nameplate parameters.

Function Code	Parameter Name	Setting Range	Default	Property
Group P1: Motor 1 Parameters				
P1-06	Stator resistance (asynchronous motor)	0.001–65.535 Ω (AC drive power ≤ 55 kW)	Model dependent	★
P1-07	Rotor resistance (asynchronous motor)	0.001–65.535 Ω (AC drive power ≤ 55 kW)	Model Dependent	★
P1-08	Leakage inductive reactance (asynchronous motor)	0.01–655.35 mH (AC drive power ≤ 55 kW)	Model Dependent	★
P1-09	Mutual inductive reactance (asynchronous motor)	0.1–6553.5 mH (AC drive power ≤ 55 kW)	Model Dependent	★
P1-10	No-load current (asynchronous motor)	0.01 to P1-03 (AC drive power ≤ 55 kW)	Model Dependent	★

The parameters in P1-06 to P1-10 are asynchronous motor parameters. These parameters are unavailable on the motor nameplate and are obtained by means of motor auto-tuning. Only P1-06 to P1-08 can be obtained through static motor auto-tuning.



Through complete motor auto-tuning, encoder phase sequence and current loop PI can be obtained besides the parameters in P1-06 to P1-10.

Each time "Rated motor power" (P1-01) or "Rated motor voltage" (P1-02) is changed, the AC drive automatically restores values of P1-06 to P1-10 to the parameter setting for the common standard B series asynchronous motor.

If it is impossible to perform motor auto-tuning onsite, manually input the values of these parameters according to data provided by the motor manufacturer.

Function Code	Parameter Name	Setting Range	Default	Property
Group P1: Motor 1 Parameters				
P1-11	Auto-tuning selection	0: No auto-tuning 1: Asynchronous motor static auto-tuning 2: Asynchronous motor complete auto-tuning	0	★

- 0: No auto-tuning

Auto-tuning is prohibited.

- 1: Asynchronous motor static auto-tuning

It is applicable to scenarios where complete auto-tuning cannot be performed because the asynchronous motor cannot be disconnected from the load.

Before performing static auto-tuning, properly set the motor type and motor nameplate parameters of P1-00 to P1-05 first. The AC drive will obtain parameters of P1-06 to P1-08 by static auto-tuning.

Set this parameter to 1, and press  Then, the AC drive starts static auto-tuning.

- 2: Asynchronous motor complete auto-tuning

To perform this type of auto-tuning, ensure that the motor is disconnected from the load. During the process of complete auto-tuning, the AC drive performs static auto-tuning first and then accelerates to 80% of the rated motor frequency within the acceleration time set in P0-17. The AC drive keeps running for a certain period and then decelerates to stop within deceleration time set in P0-18.

Before performing complete auto-tuning, properly set the motor type, motor nameplate parameters of P1-00 to P1-05.

Set this parameter to 2, and press  Then, the AC drive starts complete autotuning.

Notes				
Motor auto-tuning can be performed only in operation panel mode.				

Group P2: Vector Control Parameters

Group P2 is valid for vector control, and invalid for V/F control.

Function Code	Parameter Name	Setting Range	Default	Property
Group P2: Vector Control Parameters				
P2-00	Speed loop proportional gain 1	0–100	30	☆
P2-01	Speed loop integral time 1	0.01–10.00s	0.50s	☆
P2-02	Switchover frequency 1	0.00 to P2-05	5.00HZ	☆
P2-03	Speed loop proportional gain 2	0–100	20	☆
P2-04	Speed loop integral time 2	0.01–10.00s	1.00s	☆
P2-05	Switchover frequency 2	P2-02 to maximum output frequency	10.0HZ	☆



Speed loop PI parameters vary with running frequencies of the AC drive.

- If the running frequency is less than or equal to "Switchover frequency 1" (P2-02), the speed loop PI parameters are P2-00 and P2-01.
- If the running frequency is equal to or greater than "Switchover frequency 2" (P2-05), the speed loop PI parameters are P2-03 and P2-04.
- If the running frequency is between P2-02 and P2-05, the speed loop PI parameters are obtained from the linear switchover between the two groups of PI parameters, as shown in Figure 6-3.

Figure 6-3 Relationship between running frequencies and PI parameters

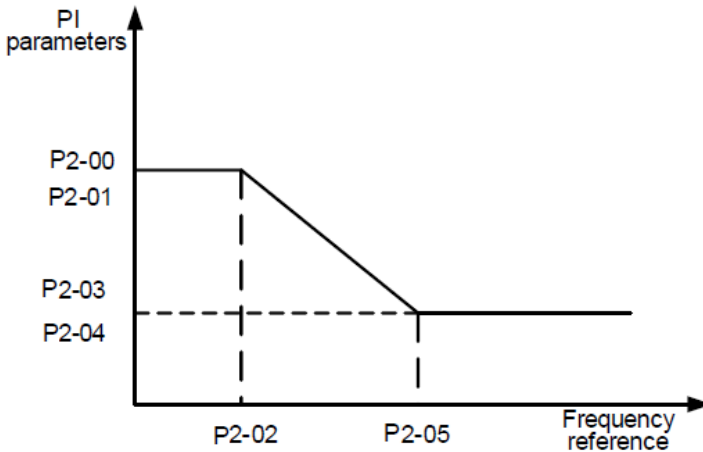

The speed dynamic response characteristics in vector control can be adjusted by setting the proportional gain and integral time of the speed regulator.

To achieve a faster system response, increase the proportional gain and reduce the integral time. Be aware that this may lead to system oscillation.

The recommended adjustment method is as follows:

If the factory setting cannot meet the requirements, make proper adjustment. Increase the proportional gain first to ensure that the system does not oscillate, and then reduce the integral time to ensure that the system has quick response and small overshoot.

Notes				
Improper PI parameter setting may cause too large speed overshoot, and overvoltage fault may even occur when the overshoot drops.				

Function Code	Parameter Name	Setting Range	Default	Property
Group P2: Vector Control Parameters				
P2-06	Time constant of speed loop filter	0.000–0.100s	0.000s	☆

For SFVC, it is used to adjust speed stability accuracy of the motor. When the motor with load runs at a very low speed, increase the value of this parameter; when the motor with load runs at a very large speed, decrease the value of this parameter.



Function Code	Parameter Name	Setting Range	Default	Property
Group P2: Vector Control Parameters				
P2-07	Vector control slip gain	50%–200%	100%	☆

In the vector control mode, the output of the speed loop regulator is torque current reference. This parameter is used to filter the torque references. It need not be adjusted generally and can be increased in the case of large speed fluctuation. In the case of motor oscillation, decrease the value of this parameter properly.

If the value of this parameter is small, the output torque of the AC drive may fluctuate greatly, but the response is quick.

Function Code	Parameter Name	Setting Range	Default	Property
Group P2: Vector Control Parameters				
P2-08	Vector control overexcitation gain	0–200	64	☆

During deceleration of the AC drive, over-excitation control can restrain rise of the bus voltage to avoid the overvoltage fault. The larger the over-excitation gain is, the better the restraining effect is.

Increase the over-excitation gain if the AC drive is liable to overvoltage error during deceleration. Too large over-excitation gain, however, may lead to an increase in output current. Therefore, set this parameter to a proper value in actual applications.

Set the over-excitation gain to 0 in applications of small inertia (the bus voltage will not rise during deceleration) or where there is a braking resistor.

Function Code	Parameter Name	Setting Range	Default	Property
Group P2: Vector Control Parameters				
P2-09	Digital setting of torque upper limit in speed control mode	0.0%–200.0%	150%	☆
P2-10	Torque upper limit source in speed control mode	0: P2-10 1: AI1 2: AI2 3: Reserved 4: Pulse setting (DI5) 5: Communication setting	0	☆

In the speed control mode, the maximum output torque of the AC drive is restricted by P2-10. If the torque upper limit is analog, pulse or communication setting, 100% of the setting corresponds to the value of P2-09, and 100% of the value of P2-09 corresponds to the AC drive rated torque.

For details on the AI1, AI2 setting, see the description of the AI curves in group P4.

For details on the pulse setting, see the description of P4-28 to P4-32.

When the AC drive is in communication with the master, if P2-10 is set to 5 “communication setting”, P2-09 “Digital setting of torque upper limit in speed control mode” can be set via communication from the master.

In other conditions, the host computer writes data -100.00% to 100.00% by the communication address 0x1000, where 100.0% corresponds to the value of P2-09. The communication protocol can be Modbus.

Function Code	Parameter Name	Setting Range	Default
P2-13	Excitation adjustment proportional gain	0~60000	2000
P2-14	Excitation adjustment integral gain	0~60000	1300
P2-15	Torque adjustment proportional gain	0~60000	2000
P2-16	Torque adjustment integral gain	0~60000	1300



These are current loop PI parameters for vector control. These parameters are automatically obtained through "Asynchronous motor complete auto-tuning".and need not be modified.

The dimension of the current loop integral regulator is integral gain rather than integral time.

Notes				
that too large current loop PI gain may lead to oscillation of the entire control loop. Therefore, when current oscillation or torque fluctuation is great, manually decrease the proportional gain or integral gain here.				

Function Code	Parameter Name	Setting Range	Default	Property
Group P2: Vector Control Parameters				
P2-17	Speed loop integral property	Unit's digit: integral separation 0: Disabled 1: Enabled	0	☆

Group P3: V/F Control Parameters

Group P3 is valid only for V/F control.

The V/F control mode is applicable to low load applications (fan or pump) or applications where one AC drive operates multiple motors or there is a large difference between the AC drive power and the motor power.

Function Code	Parameter Name	Setting Range	Default	Property
Group P3: V/F Control Parameters				
P3-00	Cut-off frequency of torque boost	0.00 Hz to maximum output frequency	50.0HZ	★
P3-01	Torque boost	0.0% (fixed torque boost) 0.1%–30.0%	Model dependent	☆

To compensate the low frequency torque characteristics of V/F control, you can boost the output voltage of the AC drive at low frequency by modifying P3-01.

If the torque boost is set to too large, the motor may overheat, and the AC drive may suffer overcurrent.

If the load is large and the motor startup torque is insufficient, increase the value of P3-01. If the load is small, decrease the value of P3-01. If it is set to 0.0, the AC drive performs automatic torque boost. In this case, the AC drive automatically calculates the torque boost value based on motor parameters including the stator resistance.

P3-00 specifies the frequency under which torque boost is valid. Torque boost becomes invalid when this frequency is exceeded, as shown in the following figure.

Figure 6-4 Manual torque boost

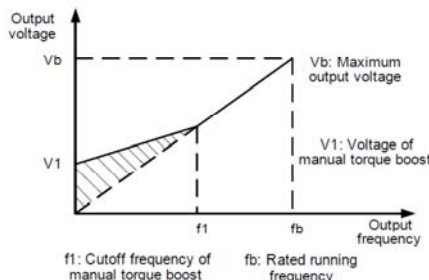



Function Code	Parameter Name	Setting Range	Default	Property
Group P3: V/F Control Parameters				
P3-02	V/F curve setting	0: Linear V/F 1: Multi-point V/F 2: Square V/F 3: 1.2-power V/F 4: 1.4-power V/F 6: 1.6-power V/F 8: 1.8-power V/F	0	★

- 0: Linear V/F

It is applicable to common constant torque load.

- 1: Multi-point V/F

It is applicable to special load such as dehydrator and centrifuge. Any such V/F curve can be obtained by setting parameters of P3-03 to P3-08.

- 2: Square V/F

It is applicable to centrifugal loads such as fan and pump.

- 3 to 8: V/F curve between linear V/F and square V/F

Function Code	Parameter Name	Setting Range	Default	Property
Group P3: V/F Control Parameters				
P3-03	Multi-point V/F frequency 1 (F1)	0.00 Hz to P3-05	0.00 Hz	★
P3-04	Multi-point V/F voltage 1 (V1)	0.0%–100.0%	0.0%	★
P3-05	Multi-point V/F frequency 2 (F2)	P3-03 to P3-07	0.00 Hz	★
P3-06	Multi-point V/F voltage 2 (V2)	0.0%–100.0%	0.0%	★
P3-07	Multi-point V/F frequency 3 (F3)	P3-05 to rated motor frequency (P1-04)	0.00 Hz	★
P3-08	Multi-point V/F voltage 3 (V3)	0.0%–100.0%	0.0%	★

These six parameters are used to define the multi-point V/F curve.

The multi-point V/F curve is set based on the motor's load characteristic. The relationship between voltages and frequencies is:

$$V1 < V2 < V3, F1 < F2 < F3$$

At low frequency, higher voltage may cause overheat or even burnt out of the motor and overcurrent stall or overcurrent protection of the AC drive.

Figure 6-5 Setting of multi-point V/F curve

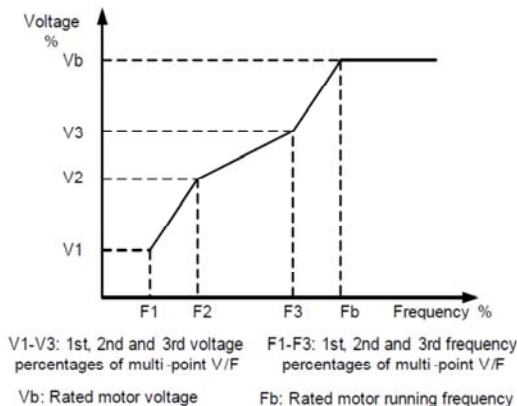



Function Code	Parameter Name	Setting Range	Default	Property
Group P3: V/F Control Parameters				
P3-09	V/F slip compensation gain	0%~200.0%	0.0%	☆

This parameter is valid only for the asynchronous motor.

It can compensate the rotational speed slip of the asynchronous motor when the load of the motor increases, stabilizing the motor speed in case of load change. If this parameter is set to 100%, it indicates that the compensation when the motor bears rated load is the rated motor slip. The rated motor slip is automatically obtained by the AC drive through calculation based on the rated motor frequency and rated motor rotational speed in group P1.

Generally, if the motor rotational speed is different from the target speed, slightly adjust this parameter.

Function Code	Parameter Name	Setting Range	Default	Property
Group P3: V/F Control Parameters				
P3-10	V/F over-excitation gain	0~200	64	☆

During deceleration of the AC drive, over-excitation can restrain rise of the bus voltage, preventing the overvoltage fault. The larger the over-excitation is, the better the restraining result is.

Increase the over-excitation gain if the AC drive is liable to overvoltage error during deceleration. However, too large over-excitation gain may lead to an increase in the output current. Set P3-09 to a proper value in actual applications.

Set the over-excitation gain to 0 in the applications where the inertia is small and the bus voltage will not rise during motor deceleration or where there is a braking resistor.

Function Code	Parameter Name	Setting Range	Default	Property
Group P3: V/F Control Parameters				
P3-11	V/F oscillation suppression gain	0~100	Model dependent	☆

Set this parameter to a value as small as possible in the prerequisite of efficient oscillation suppression to avoid influence on V/F control.

Set this parameter to 0 if the motor has no oscillation. Increase the value properly only when the motor has obvious oscillation. The larger the value is, the better the oscillation suppression result will be.

When the oscillation suppression function is enabled, the rated motor current and no-load current must be correct. Otherwise, the V/F oscillation suppression effect will not be satisfactory.

Group P4: Input Terminals

The SSI700 provides five DI terminals (DI5 can be used for high-speed pulse input) and 3analog input (AI) terminals.

Function Code	Parameter Name	Default	Remark
Group P4: Input Terminals			
P4-00	DI1 function selection	1: Forward RUN (FWD)	Standard
P4-01	DI2 function selection	2: Reverse RUN (REV)	Standard
P4-02	DI3 function selection	9: Fault reset (RESET)	Standard
P4-03	DI4 function selection	12: Multi-reference terminal 1	Standard
P4-04	DI5 function selection	13: Multi-reference terminal 2	Standard

The following table lists the functions available for the DI terminals.

16

Table 6-1 Functions of DI terminals

Value	Function	Description
0	No function	Set 0 for reserved terminals to avoid malfunction.
1	Forward RUN (FWD)	The terminal is used to control forward or reverse RUN of the AC drive.
2	Reverse RUN (REV)	
3	Three-line control	The terminal determines three-line control of the AC drive. For details, see the description of P4-11.
4	Forward JOG (FJOG)	FJOG indicates forward JOG running, while RJOG indicates reverse JOG running. The JOG frequency, acceleration time and deceleration time are described respectively in P8-00, P8-01 and P8-02.
5	Reverse JOG (RJOG)	
6	Terminal UP	If the frequency is determined by external terminals, the terminals with the two functions are used as increment and decrement commands for frequency modification. When the frequency source is digital setting, they are used to adjust the frequency.
7	Terminal DOWN	
8	Coast to stop	The AC drive blocks its output, the motor coasts to rest and is not controlled by the AC drive. It is the same as coast to stop described in P6-10.
9	Fault reset (RESET)	The terminal is used for fault reset function, the same as the function of RESET key on the operation panel. Remote fault reset is implemented by this function.
10	RUN pause	The AC drive decelerates to stop, but the running parameters are all memorized, such as PLC, swing frequency and PID parameters. After this function is disabled, the AC drive resumes its status before stop.
11	Normally open (NO) input of external fault	If this terminal becomes ON, the AC drive reports Err and performs the fault protection action. For more details, see the description of P9-47.
12	Multi-reference terminal 1	The setting of 16 speeds or 16 other references can be implemented through combinations of 16 states of these four terminals.
13	Multi-reference terminal 2	
14	Multi-reference terminal 3	
15	Multi-reference terminal 4	
16	Terminal1 for acceleration/ deceleration time selection	Totally four groups of acceleration/deceleration time can be selected through combinations of two states of these two terminals.
17	Terminal2 for acceleration/ deceleration time selection	
18	Frequency source switchover	The terminal is used to perform switchover between two frequency sources according to the setting in P0-07
19	UP and DOWN setting clear (terminal, operation panel)	If the frequency source is digital setting, the terminal is used to clear the modification by using the UP/ DOWN function or the increment/decrement key on the operation panel, returning the set frequency to the value of P0-08.
20	Command source switchover terminal	If the command source is set to terminal control (P0-01= 1), this terminal is used to perform switchover between terminal control and operation panel control. If the command source is set to communication control (P0-01= 2), this terminal is used to perform switchover between communication control and operation panel control.
21	Acceleration/Deceleration prohibited	It enables the AC drive to maintain the current frequency output without being affected by external signals (except the STOP command).
22	PID pause	PID is invalid temporarily. The AC drive maintains the current frequency output without supporting PID adjustment of frequency source.
23	PLC status reset	The terminal is used to restore the original status of PLC control for the AC drive when PLC control is started again after a pause.

Value	Function	Description
24	Swing pause	The AC drive outputs the central frequency, and the swing frequency function pauses.
25	Counter input	This terminal is used to count pulses.
26	Counter reset	This terminal is used to clear the counter status.
27	Length count input	This terminal is used to count the length.
28	Length reset	This terminal is used to clear the length.
29	Torque control prohibited	The AC drive is prohibited from torque control and enters the speed control mode.
30	Pulse input (enabled only for DI5)	DI5 is used for pulse input.
31	Reserved	Reserved.
32	Immediate DC braking	After this terminal becomes ON, the AC drive directly switches over to the DC braking state.
33	Normally closed (NC) input of external fault	After this terminal becomes ON, the AC drive reports Err and stops.
34	Frequency modification forbidden	After this terminal becomes ON, the AC drive does not respond to any frequency modification.
35	Reverse PID action direction	After this terminal becomes ON, the PID action direction is reversed to the direction set in 10-03.
36	External STOP terminal 1	In operation panel mode, this terminal can be used to stop the AC drive, equivalent to the function of the STOP key on the operation panel.
37	Command source switchover terminal 2	It is used to perform switchover between terminal control and communication control. If the command source is terminal control, the system will switch over to communication control after this terminal becomes ON.
38	PID integral pause	After this terminal becomes ON, the integral adjustment function pauses. However, the proportional and differentiation adjustment functions are still valid.
39	Switchover between main frequency source A and preset frequency	After this terminal becomes ON, the frequency source A is replaced by the preset frequency set in P0-08.
40	Switchover between auxiliary frequency source B and preset frequency	After this terminal is enabled, the frequency source B is replaced by the preset frequency set in P0-08.
41,42	Reserved	Reserved.
43	PID parameter switchover	If the PID parameters switchover performed by means of DI terminal (10-18 =1), the PID parameters are 10-05 to 10-07 when the terminal becomes OFF; the PID parameters are 10-15 to 10-17 when this terminal becomes ON.
44,45	Reserved	Reserved.
46	Speed control/Torque control switchover	This terminal enables the AC drive to switch over between speed control and torque control. When this terminal becomes OFF, the AC drive runs in the mode set in 17-00. When this terminal becomes ON, the AC drive switches over to the other control mode.
47	Emergency stop	When this terminal becomes ON, the AC drive stops within the shortest time. During the stop process, the current remains at the set current upper limit.
48	External STOP terminal 2	In any control mode (operation panel, terminal or communication), it can be used to make the AC drive decelerate to stop. In this case, the deceleration time is deceleration time 4.
49	Deceleration DC braking	When this terminal becomes ON, the AC drive decelerates to the initial frequency of stop DC braking and then switches over to DC braking state.
50	Clear the current running time	When this terminal becomes ON, the AC drive's current running time is cleared. This function must be supported by P8-42 and P8-53.

The four multi-reference terminals have 16 state combinations, corresponding to 16 reference values, as listed in the following table.

18

Table 6-2 State combinations of the four multi-reference terminals

K4	K3	K2	K1	Reference Setting	Corresponding Parameter
OFF	OFF	OFF	OFF	Reference 0	12-00
OFF	OFF	OFF	ON	Reference 1	12-01
OFF	OFF	ON	OFF	Reference 2	12-02
OFF	OFF	ON	ON	Reference 3	12-03
OFF	ON	OFF	OFF	Reference 4	12-04
OFF	ON	OFF	ON	Reference 5	12-05
OFF	ON	ON	OFF	Reference 6	12-06
OFF	ON	ON	ON	Reference 7	12-07
ON	OFF	OFF	OFF	Reference 8	12-08
ON	OFF	OFF	ON	Reference 9	12-09
ON	OFF	ON	OFF	Reference 10	12-10
ON	OFF	ON	ON	Reference 11	12-11
ON	ON	OFF	OFF	Reference 12	12-12
ON	ON	OFF	ON	Reference 13	12-13
ON	ON	ON	OFF	Reference 14	12-14
ON	ON	ON	ON	Reference 15	12-15

If the frequency source is multi-reference, the value 100% of 12-00 to 12-15 corresponds to the value of P0-10 (Maximum frequency).

Besides the multi-speed function, the multi-reference can be also used as the PID setting source or the voltage source for V/F separation, satisfying the requirement on switchover of different setting values.

Two terminals for acceleration/deceleration time selection have four state combinations, as listed in the following table.

Table 6-3 State combinations of two terminals for acceleration/deceleration time selection

Terminal 2	Terminal 1	Acceleration/Deceleration Time Selection	Corresponding Parameters
OFF	OFF	Acceleration/Deceleration time 1	P0-17, P0-18
OFF	ON	Acceleration/Deceleration time 2	P8-03, P8-04
ON	OFF	Acceleration/Deceleration time 3	P8-05, P8-06
ON	ON	Acceleration/Deceleration time 4	P8-07, P8-08

Function Code	Parameter Name	Setting Range	Default	Property
Group P4: Input Terminals				
P4-10	DI filter time	0.000–1.000s	0.010s	☆

It is used to set the software filter time of DI terminal status. If DI terminals are liable to interference and may cause malfunction, increase the value of this parameter to enhance the anti-interference capability. However, increase of DI filter time will reduce the response of DI terminals.

Function Code	Parameter Name	Setting Range	Default	Property
Group P4: Input Terminals				
P4-11	Terminal command mode	0: Two-line mode 1 1: Two-line mode 2 2: Three-line mode 1 3: Three-line mode 2	1	★

This parameter is used to set the mode in which the AC drive is controlled by external terminals. The following uses DI1, DI2 and DI3 among DI1 to DI5 as an example, with allocating functions of DI1, DI2 and DI3 by setting P4-00 to P4-02.



- 0: Two-line mode 1

It is the most commonly used two-line mode, in which the forward/reverse rotation of the motor is decided by DI1 and DI2. The parameters are set as below:

Function Code	Parameter Name	Value	Function Description
P4-11	Terminal command mode	0	Two-line 1
P4-00	DI1 function selection	1	Forward RUN (FWD)
P4-01	DI2 function selection	2	Reverse RUN (REV)

Figure 6-7 Setting of two-line mode 1

K1	K2	RUN command
1	0	Forward RUN
0	1	Reverse RUN
1	1	Stop
0	0	Stop

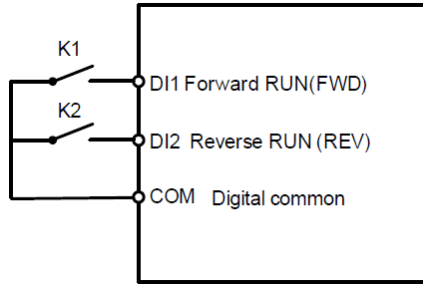

As shown in the preceding figure, when only K1 is ON, the AC drive instructs forward rotation. When only K2 is ON, the AC drive instructs reverse rotation. When K1 and K2 are ON or OFF simultaneously, the AC drive stops.

- **1: Two-line mode 2**

In this mode, DI1 is RUN enabled terminal, and DI2 determines the running direction. The parameters are set as below:

Function Code	Parameter Name	Value	Function Description
P4-11	Terminal command mode	1	Two-line 1
P4-00	DI1 function selection	1	Forward RUN (FWD)
P4-01	DI2 function selection	2	Reverse RUN (REV)

Figure 6-8 Setting of two-line mode 2

K1	K2	RUN command
1	0	Forward RUN
1	1	Reverse RUN
0	0	Stop
0	1	Stop

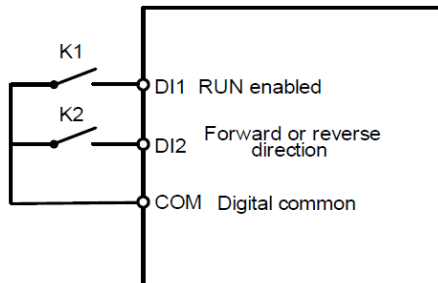

As shown in the preceding figure, if K1 is ON, the AC drive instructs forward rotation when K2 is OFF, and instructs reverse rotation when K2 is ON. If K1 is OFF, the AC drive stops.

- **2: Three-line mode 1**

In this mode, DI3 is RUN enabled terminal, and the direction is decided by DI1 and DI2. The parameters are set as below:



Function Code	Parameter Name	Value	Function Description
P4-11	Terminal command mode	2	Two-line 1
P4-00	DI1 function selection	1	Forward RUN (FWD)
P4-01	DI2 function selection	2	Reverse RUN (REV)
P4-02	DI3 function selection	3	Three-line control

Figure 6-9 Setting of three-line mode 1

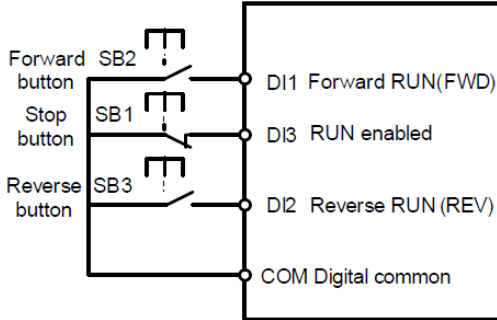

As shown in the preceding figure, if SB1 is ON, the AC drive instructs forward rotation when SB2 is pressed to be ON and instructs reverse rotation when SB3 is pressed to be ON. The AC drive stops immediately after SB1 becomes OFF. During normal startup and running, SB1 must remain ON. The AC drive's running state is determined by the final actions on SB1, SB2 and SB3.

• 3: Three-line mode 2

In this mode, DI3 is RUN enabled terminal. The RUN command is given by DI1 and the direction is decided by DI2. The parameters are set as below:

Function Code	Parameter Name	Value	Function Description
P4-11	Terminal command mode	3	Two-line 2
P4-00	DI1 function selection	1	Forward RUN (FWD)
P4-01	DI2 function selection	2	Reverse RUN (REV)
P4-02	DI3 function selection	3	Three-line control

Figure 6-10 Setting of three-line mode 2

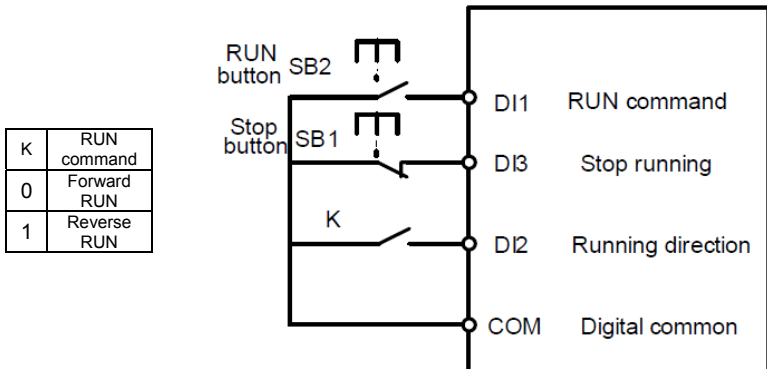



As shown in the preceding figure, if SB1 is ON, the AC drive starts running when SB2 is pressed to be ON; the AC drive instructs forward rotation when K is OFF and instructs reverse rotation when K is ON. The AC drive stops immediately after SB1 becomes OFF. During normal startup and running, SB1 must remain ON. The AC drive's running state is determined by the final actions of SB1, SB2 and K.

Function Code	Parameter Name	Setting Range	Default	Property
Group P4: Input Terminals				
P4-12	Terminal UP/DOWN rate	0.01–65.535 Hz/s	1.0 Hz/s	☆

It is used to adjust the rate of change of frequency when the frequency is adjusted by means of terminal UP/DOWN.

- If P0-22(Frequency reference resolution)is 2, the setting range is 0.001–65.535 Hz/s.
- If P0-22 (Frequency reference resolution) is 1, the setting range is 0.01–655.35 Hz/s.

Function Code	Parameter Name	Setting Range	Default	Property
Group P4: Input Terminals				
P4-13	AI1curve minimum input	0.00 V to P4-15	0.00 V	☆
P4-14	Corresponding setting of AI curve 1 minimum input	-100.00%+100.0%	0.0%	☆
P4-15	AI1curve maximum input	P4-13 to 10.00 V	10.00V	☆
P4-16	Corresponding setting of AI1curve maximum input	-100.00%+100.0%	100.0 %	☆
P4-17	AI1 filter time	0.00–10.00s	0.10s	☆

These parameters are used to define the relationship between the analog input voltage and the corresponding setting. When the analog input voltage exceeds the maximum value(P4-15), the maximum value is used. When the analog input voltage is less than the minimum value(P4-13), the value set in P4-34(Setting for AI less than minimum input) is used. When the analog input is current input, 1 mA current corresponds to 0.5 V voltage.

P4-17 (AI1 filter time) is used to set the software filter time of AI1. If the analog input is liable to interference, increase the value of this parameter to stabilize the detected analog input. However, increase of the AI filter time will slow the response of analog detection. Set this parameter properly based on actual conditions.

In different applications, 100% of analog input corresponds to different nominal values. For details, refer to the description of different applications.

Two typical setting examples are shown in the following figure.

Figure 6-11 Corresponding relationship between analog input and set values

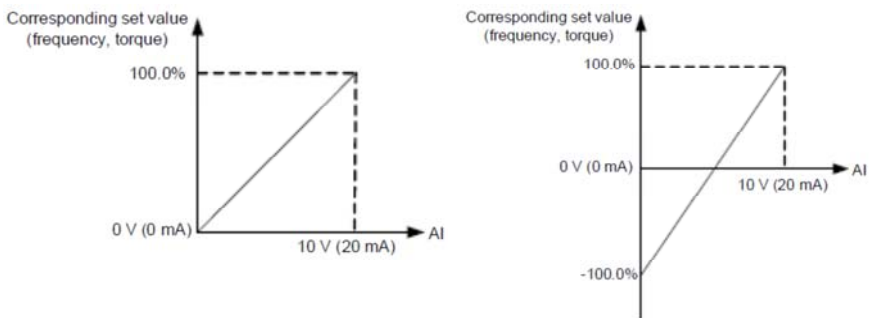



Function Code	Parameter Name	Setting Range	Default	Property
Group P4: Input Terminals				
P4-18	AI2 curve minimum input	0.00 V to P4-20	0.00 V	☆
P4-19	Corresponding setting of AI2 curve minimum input	-100.00%+100.0%	0.0%	☆
P4-20	AI2 curve maximum input	P4-18 to 10.00 V	10.00V	☆
P4-21	Corresponding setting of AI2 curve maximum input	-100.00%+100.0%	100.0 %	☆
P4-22	AI2 filter time	0.00–10.00s	0.10s	☆

The method of setting AI2 functions is similar to that of setting AI1 function.

Function Code	Parameter Name	Setting Range	Default	Property
Group P4: Input Terminals				
P4-28	Pulse minimum input	0.00 kHz to P4-30	0.00 kHz	☆
P4-29	Corresponding setting of pulse minimum input	-100.00%–100.0%	0.0%	☆
P4-30	Pulse maximum input	P4-28 to 50.00 kHz	50.00 kHz	☆
P4-31	Corresponding setting of pulse maximum input	-100.00%+100.0%	100.0 %	☆
P4-32	Pulse filter time	0.00–10.00s	0.10s	☆

These parameters are used to set the relationship between DI5 pulse input and corresponding settings. The pulses can only be input by DI5. The method of setting this function is similar to that of setting AI1 function.

Function Code	Parameter Name	Setting Range	Default	Property
P4-33	AI curve selection	Unit's digit (AI1 curve selection)	321	☆
		Curve 1 (2 points, see P4-13 to P4-16)		
		Curve 2 (2 points, see P4-18 to P4-21)		
		Ten's digit (AI2 curve selection)		
		Curve1 to curve 5 (same as AI1)		

The unit's digit, ten's digit and hundred's digit of this parameter are respectively used to select the corresponding curve of AI1, AI2. Any of the five curves can be selected for AI1, AI2.

Curve 1, curve 2 and curve 3 are all 2-point curves, set in group P4. Curve 4 and curve 5 are both 4-point curves. The SSI700 provides two AI terminals as standard.

Function Code	Parameter Name	Setting Range	Default	Property
Group P4: Input Terminals				
P4-34	Setting for AI less than minimum input	Unit's digit (Setting for AI1 less than minimum input)	000	☆
		0: Minimum value 1: 0.0%		
		Ten's digit (Setting for AI2 less than minimum input)		
		0, 1 (same as AI1)		

This parameter is used to determine the corresponding setting when the analog input voltage is less than the minimum value. The unit's digit, ten's digit and hundred's digit of this parameter respectively correspond to the setting for AI2, AI2.

If the value of a certain digit is 0, when analog input voltage is less than the minimum input, the corresponding setting of the minimum input (P4-14, P4-19, P4-24) is used.

If the value of a certain digit is 1, when analog input voltage is less than the minimum input, the corresponding value of this analog input is 0.0%.

23

Function Code	Parameter Name	Setting Range	Default	Property
Group P4: Input Terminals				
P4-35	DI1 delay time	0.0–3600.0s	0.0s	★
P4-36	DI2 delay time	0.0–3600.0s	0.0s	★

These parameters are used to set the delay time of the AC drive when the status of DI terminals changes.

Currently, only DI1, DI2 support the delay time function.

Function Code	Parameter Name	Setting Range	Default	Property
P4-38	DI valid mode selection1	Unit's digit (DI1 valid mode)	00000	★
		0: High level valid		
		1: Low level valid		
		Ten's digit (DI2 valid mode)		
		0, 1 (same as DI1)		
		Hundred's digit (DI3 valid mode)		
		0, 1 (same as DI1)		
		Thousand's digit (DI4 valid mode)		
		0, 1 (same as DI1)		
Ten thousand's digit (DI5 valid mode)				
0, 1 (same as DI1)				

These parameters are used to set the valid mode of DI terminals.

- 0: High level valid

The DI terminal is valid when being connected with COM, and invalid when being disconnected from COM.

- 1: Low level valid

The DI terminal is invalid when being connected with COM, and invalid when being disconnected from COM.

Group F5: Output Terminals

The SSI700 provides an analog output (AO) terminal, a digital output (DO) terminal, a relay terminal and a FM terminal (used for high-speed pulse output or open-collector switch signal output) as standard.

Function Code	Parameter Name	Setting Range	Default	Property
Group P5: Output Terminals				
P5-00	FM terminal output mode	0: Pulse output (FMP) 1: Switch signal output (FMR)	0	☆

The FM terminal is programmable multiplexing terminal. It can be used for high-speed pulse output (FMP), with maximum frequency of 100Hz. Refer to P5-06 for relevant functions of FMP. It can also be used as open collector switch signal output (FMR).

Function Code	Parameter Name	Default
P5-01	FMR function (opencollector output terminal)	0
P5-02	Relay function (T/A-T/B-T/C)	2
P5-04	DO1 function selection (open-collector output terminal)	4

These five parameters are used to select the functions of the five digital output terminals. T/A-T/B-T/C are respectively the relays on the control board .

The functions of the output terminals are described in the following table.

Table 6-5 Functions of output terminals

Value	Function	Description
0	No output	The terminal has no function.
1	AC drive running	When the AC drive is running and has output frequency (can be zero), the terminal becomes ON.
2	Fault output (stop)	When the AC drive stops due to a fault, the terminal becomes ON.
3	Frequency-level detection BRAKE control 1 output	Refer to the descriptions of P8-19 and P8-20.
4	Frequency reached	Refer to the descriptions of P8-21.
5	Zero-speed running (no output at stop)	If the AC drive runs with the output frequency of 0, the terminal becomes ON. If the AC drive is in the stop state, the terminal becomes OFF.
6	Motor overload pre-warning	The AC drive judges whether the motor load exceeds the overload pre-warning threshold before performing the protection action. If the pre-warning threshold is exceeded, the terminal becomes ON. For motor overload parameters, see the descriptions of P9-00 to P9-02.
7	AC drive overload prewarning	The terminal becomes ON 10s before the AC drive overload protection action is performed.
8	Set count value reached	The terminal becomes ON when the count value reaches the value set in 11-08.
9	Designated count value reached	The terminal becomes ON when the count value reaches the value set in 11-09.
10	Length reached	The terminal becomes ON when the detected actual length exceeds the value set in 11-05.
11	PLC cycle complete	When simple PLC completes one cycle, the terminal outputs a pulse signal with width of 250 ms.
12	Accumulative running time reached	If the accumulative running time of the AC drive exceeds the time set in P8-17, the terminal becomes ON.
13	Frequency limited	If the set frequency exceeds the frequency upper limit or lower limit and the output frequency of the AC drive reaches the upper limit or lower limit, the terminal becomes ON.
14	Torque limited	In speed control mode, if the output torque reaches the torque limit, the AC drive enters the stall protection state and meanwhile the terminal becomes ON.
15	Ready for RUN	If the AC drive main circuit and control circuit become stable, and the AC drive detects no fault and is ready for RUN, the terminal becomes ON.
16	AI1 larger than AI2	When the input of AI1 is larger than the input of AI2, the terminal becomes ON.
17	Frequency upper limit reached	If the running frequency reaches the upper limit, the terminal becomes ON.
18	Frequency lower limit reached (no output at stop)	If the running frequency reaches the lower limit, the terminal becomes ON. In the stop state, the terminal becomes OFF.
19	Undervoltage state output	If the AC drive is in undervoltage state, the terminal becomes ON.
20	Communication	setting Refer to the communication protocol.
21,22	Reserved	Reserved.
23	Zero-speed running 2 (having output at stop)	If the output frequency of the AC drive is 0, the terminal becomes ON. In the state of stop, the signal is still ON.
24	Accumulative poweron time reached	If the AC drive accumulative power-on time (P7-13) exceeds the value set in P8-16, the terminal becomes ON.
25	Frequency level detection BRAKE control 2 output	Refer to the descriptions of P8-28 and P8-29.

Value	Function	Description
26	Frequency 1 reached	Refer to the descriptions of P8-30 and P8-31.
27	Frequency 2 reached	Refer to the descriptions of P8-32 and P8-33.
28	Current 1 reached	Refer to the descriptions of P8-38 and P8-39.
29	Current 2 reached	Refer to the descriptions of P8-40 and P8-41.
30	Timing reached	If the timing function (P8-42) is valid, the terminal becomes ON after the current running time of the AC drive reaches the set time.
31	AI1 input limit exceeded	If AI1 input is larger than the value of P8-46 (AI1 input voltage upper limit) or lower than the value of P8-45 (AI1 input voltage lower limit), the terminal becomes ON.
32	Load becoming 0	If the load becomes 0, the terminal becomes ON.
33	Reverse running	If the AC drive is in the reverse running state, the terminal becomes ON.
34	Zero current state	Refer to the descriptions of P8-28 and P8-29.
35	Module temperature reached	If the heatsink temperature of the inverter module (P7-07) reaches the set module temperature threshold (P8-47), the terminal becomes ON.
36	Software current limit	exceeded Refer to the descriptions of P8-36 and P8-37.
37	Frequency lower limit reached (having output at stop)	If the running frequency reaches the lower limit, the terminal becomes ON. In the stop state, the signal is still ON.
38	Alarm output	If a fault occurs on the AC drive and the AC drive continues to run, the terminal outputs the alarm signal.
39	Motor overheat warning	If the motor temperature reaches the temperature set in P9-58 (Motor overheat warning threshold), the terminal becomes ON. You can view the motor temperature by using .
40	Current running time reached	If the current running time of AC drive exceeds the value of P8-53, the terminal becomes ON.

Function Code	Parameter Name	Default
Group P5: Output Terminals		
P5-06	FMP function selection	0: Running frequency
P5-07	AO1 function selection	

The output pulse frequency of the FMP terminal ranges from 0.01 kHz to "Maximum FMP output frequency" (P5-09). The value of P5-09 is between 0.01 kHz and 100.00 kHz.

The output range of AO1. The relationship between pulse and analog output ranges and corresponding functions is listed in the following table.

Table 6-6 Relationship between pulse and analog output ranges and corresponding functions

Value	Function	Range (Corresponding to Pulse or Analog Output Range 0.0%–100.0%)
0	Running frequency	0 to maximum output frequency
1	Set frequency	0 to maximum output frequency
2	Output current	0 to 2 times of rated motor current
3	Output torque (absolute value)	0 to 2 times of rated motor torque
4	Output power	0 to 2 times of rated power
5	Output voltage	0 to 1.2 times of rated AC drive voltage
6	Pulse input	0.01–100.00 kHz
7	AI1	0–10 V
8	AI2	0–10 V (or 0–20 mA)
9	Reserved	
10	Length	0 to maximum set length
11	Count value	0 to maximum count value
12	Communication setting	0.0%–100.0%

Value	Function	Range (Corresponding to Pulse or Analog Output Range 0.0%–100.0%)
13	Motor rotational speed	0 to rotational speed corresponding to maximum output frequency
14	Output current	0.0–1000.0 A
15	Output voltage	0.0–000.0 V
16	reserved	

Function Code	Parameter Name	Setting Range	Default	Property
Group P5: Output Terminals				
P5-09	Maximum FMP output frequency	0.01–100.00 kHz	50.00 kHz	☆

If the FM terminal is used for pulse output, this parameter is used to set the maximum frequency of pulse output.

Function Code	Parameter Name	Setting Range	Default	Property
Group P5: Output Terminals				
P5-10	AO1 offset coefficient	-100.0%–100.0%	0.0%	☆
P5-11	AO1 gain	-10.00–10.00	1.00	☆

These parameters are used to correct the zero drift of analog output and the output amplitude deviation. They can also be used to define the desired AO curve.

If "b" represents zero offset, "k" represents gain, "B" represents actual output, and "A" represents standard output, the actual output is: $B = kA + b$.

The zero offset coefficient 100% of AO1 corresponds to 10 V (or 20 mA). The standard output refers to the value corresponding to the analog output of 0 to 10 V (or 0 to 20 mA) with no zero offset or gain adjustment.

For example, if the analog output is used as the running frequency, and it is expected that the output is 8 V when the frequency is 0 and 3 V at the maximum frequency, the gain shall be set to -0.50, and the zero offset shall be set to 80%.

Function Code	Parameter Name	Setting Range	Default	Property
Group P5: Output Terminals				
P5-17	FMR output delay time	0.0–3600.0s	0.0s	☆
P5-18	Relay output delay time	0.0–3600.0s	0.0s	☆
P5-20	DO1 output delay time	0.0–3600.0s	0.0s	☆

These parameters are used to set the delay time of output terminals FMR, relay, DO1 from status change to actual output.

Function Code	Parameter Name	Setting Range	Default	Property
Group P5: Output Terminals				
P5-22	DO valid mode selection	Unit's digit (FMR valid mode)	00000	☆
		0: Positive logic		
		1: Negative logic		
		Ten's digit (Relay valid mode)		
		0, 1 (same as FMR)		
Thousand's digit (DO1 valid mode)				
0, 1 (same as FMR)				

It is used to set the logic of output terminals FMR, relay, DO1.

- 0: Positive logic

The output terminal is valid when being connected with COM, and invalid when being disconnected from COM.

- 1: Positive logic

The output terminal is invalid when being connected with COM, and valid when being disconnected from COM.

Group P6: Start/Stop Control

Function Code	Parameter Name	Setting Range	Default	Property
Group P6: Start/Stop Control				
P6-00	Start mode	0: Direct start 1: Rotational speed tracking restart 2: Pre-excited start (asynchronous motor)	0	☆

- 0: Direct start

— If the DC braking time is set to 0, the AC drive starts to run at the startup frequency.

— If the DC braking time is not 0, the AC drive performs DC braking first and then starts to run at the startup frequency. It is applicable to small-inertia load application where the motor is likely to rotate at startup.

- 1: Rotational speed tracking restart

The AC drive judges the rotational speed and direction of the motor first and then starts at the tracked frequency. Such smooth start has no impact on the rotating motor. It is applicable to the restart upon instantaneous power failure of large-inertia load. To ensure the performance of rotational speed tracking restart, set the motor parameters in group P1 correctly.

- 2: Pre-excited start (asynchronous motor)

It is valid only for asynchronous motor and used for building the magnetic field before the motor runs. For pre-excited current and pre-excited time, see parameters of P6-05 and P6-06.

— If the pre-excited time is 0, the AC drive cancels pre-excitation and starts to run at startup frequency.

— If the pre-excited time is not 0, the AC drive pre-excites first before startup, improving the dynamic response of the motor.

Function Code	Parameter Name	Setting Range	Default	Property
Group P6: Start/Stop Control				
P6-01	Startup frequency	0.00–10.00 Hz	0.00 Hz	☆
P6-04	Startup frequency holdingtime	0.0–100.0s	0.0s	★

To ensure the motor torque at AC drive startup, set a proper startup frequency. In addition, to build excitation when the motor starts up, the startup frequency must be held for a certain period.

The startup frequency (P6-01) is not restricted by the frequency lower limit. If the set target frequency is lower than the startup frequency, the AC drive will not start and stays in the standby state.

During switchover between forward rotation and reverse rotation, the startup frequency holding time is disabled. The holding time is not included in the acceleration time but in the running time of simple PLC.



Example 1:

P0-00 = 0	The frequency source is digital setting.
P0-08 = 2.00 Hz	The digital setting frequency is 2.00 Hz.
P0-00 = 5.00 Hz	The startup frequency is 5.00 Hz.
P6-04 = 2.0s	The startup frequency holding time is 2.0s.

In this example, the AC drive stays in the standby state and the output frequency is 0.00Hz.

Example 2:

P0-00 = 0	The frequency source is digital setting.
P0-08 = 10.00 Hz	The digital setting frequency is 10.00 Hz.
P0-00 = 5.00 Hz	The startup frequency is 5.00 Hz.
P6-04 = 2.0s	The startup frequency holding time is 2.0s.

In this example, the AC drive accelerates to 5.00 Hz, and then accelerates to the set frequency 10.00 Hz after 2s.

Function Code	Parameter Name	Setting Range	Default	Property
Group P6: Start/Stop Control				
P6-02	Rotational speed tracking mode	0: From frequency at stop 1: From zero speed 2: From maximum frequency	0	★

To complete the rotational speed tracking process within the shortest time, select the proper mode in which the AC drive tracks the motor rotational speed.

- 0: From frequency at stop

It is the commonly selected mode.

- 1: From zero frequency

It is applicable to restart after a long time of power failure.

- 2: From the maximum frequency

It is applicable to the power-generating load.

Function Code	Parameter Name	Setting Range	Default	Property
Group P6: Start/Stop Control				
P6-03	Rotational speed tracking speed	1–100	20	☆

In the rotational speed tracking restart mode, select the rotational speed tracking speed. The larger the value is, the faster the tracking is. However, too large value may cause unreliable tracking.

Function Code	Parameter Name	Setting Range	Default
Group P6: Start/Stop Control			
P6-05	Startup DC braking current/Pre-excited current	0%–100%	0%
P6-06	Startup DC braking time/Pre-excited time	0.0–100.0s	0.0s

Startup DC braking is generally used during restart of the AC drive after the rotating motor stops. Pre-excitation is used to make the AC drive build magnetic field for the asynchronous motor before startup to improve the responsiveness.

Startup DC braking is valid only for direct start (P6-00 = 0). In this case, the AC drive performs DC braking at the set startup DC braking current. After the startup DC braking time, the AC drive starts to run. If the startup DC braking time is 0, the AC drive starts directly without DC braking. The larger the startup DC braking current is, the larger the braking force is.

If the startup mode is pre-excited start (P6-00 = 3), the AC drive builds magnetic field based on the set pre-excited current. After the pre-excited time, the AC drive starts to run. If the pre-excited time is 0, the AC drive starts directly without pre-excitation.

The startup DC braking current or pre-excited current is a percentage relative to the base value.

- If the rated motor current is less than or equal to 80% of the rated AC drive current, the base value is the rated motor current.
- If the rated motor current is greater than 80% of the rated AC drive current, the base value is 80% of the rated AC drive current.

Function Code	Parameter Name	Setting Range	Default	Property
Group P6: Start/Stop Control				
P6-07	Acceleration/Deceleration mode	0: Linear acceleration/deceleration 1: S-curve acceleration/deceleration A 2: S-curve acceleration/deceleration B	0	★

It is used to set the frequency change mode during the AC drive start and stop process.

- 0: Linear acceleration/deceleration

The output frequency increases or decreases in linear mode. The SSI700 provides four group of acceleration/deceleration time, which can be selected by using P4-00 to P4-08.

- 1: S-curve acceleration/deceleration A

The output frequency increases or decreases along the S curve. This mode is generally used in the applications where start and stop processes are relatively smooth, such as elevator and conveyor belt. P6-08 and P6-09 respectively define the time proportions of the start segment and the end segment.

- 2: S-curve acceleration/deceleration B

In this curve, the rated motor frequency f_b is always the inflexion point. This mode is usually used in applications where acceleration/deceleration is required at the speed higher than the rated frequency.

When the set frequency is higher than the rated frequency, the acceleration/ deceleration time is:

$$t = \left(\frac{4}{9} \times \left(\frac{f}{f_b} \right)^2 + \frac{5}{9} \right) \times T$$

In the formula, f is the set frequency, f_b is the rated motor frequency and T is the acceleration time from 0 Hz to f_b .

Function Code	Parameter Name	Setting Range	Default
Group P6: Start/Stop Control			
P6-08	Time proportion of S-curve start segment	0.0% to (100.0% – P6-09)	30.0%
P6-09	Time proportion of S-curve end segment	0.0% to (100.0% – P6-08)	30.0%

These two parameters respectively define the time proportions of the start segment and the end segment of S-curve acceleration/deceleration. They must satisfy the requirement: $P6-08 + P6-09 \leq 100.0\%$.

In Figure 6-12, t_1 is the time defined in P6-08, within which the slope of the output frequency change increases gradually. t_2 is the time defined in P6-09, within which the slope of the output frequency change gradually decreases to 0. Within the time between

t1 and t2, the slope of the output frequency change remains unchanged, that is, linear acceleration/deceleration.



Figure 6-12 S-curve acceleration/deceleration A

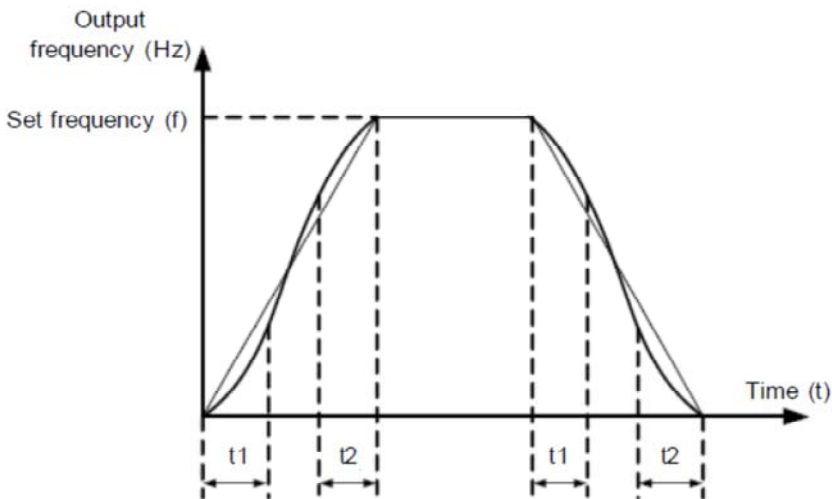
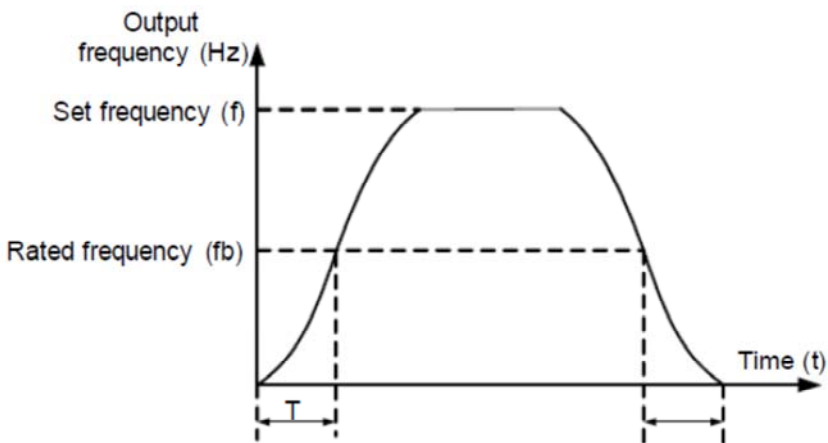

Figure 6-13 S-curve acceleration/deceleration B



Function Code	Parameter Name	Setting Range	Default	Property
Group P6: Start/Stop Control				
P6-10	Stop mode	0: Decelerate to stop 1: Coast to stop	0	☆

- 0: Decelerate to stop

After the stop command is enabled, the AC drive decreases the output frequency according to the deceleration time and stops when the frequency decreases to zero.

- 1: Coast to stop

After the stop command is enabled, the AC drive immediately stops the output. The motor will coast to stop based on the mechanical inertia.

31

Function Code	Parameter Name	Setting Range	Default	Property
Group P6: Start/Stop Control				
P6-11	Initial frequency of stop DC braking	0.00 Hz to maximum frequency	0.00 Hz	☆
P6-12	Waiting time of stop DC braking	0.0–100.0s	0.0s	☆
P6-13	Stop DC braking current	0%–100%	0%	☆
P6-14	Stop DC braking time	0.0–100.0s	0.0s	☆

- P6-11 (Initial frequency of stop DC braking)

During the process of decelerating to stop, the AC drive starts DC braking when the running frequency is lower than the value set in P6-11.

- P6-12 (Waiting time of stop DC braking)

When the running frequency decreases to the initial frequency of stop DC braking, the AC drive stops output for a certain period and then starts DC braking. This prevents faults such as overcurrent caused due to DC braking at high speed.

- P6-13 (Stop DC braking current)

This parameter specifies the output current at DC braking and is a percentage relative to the base value.

— If the rated motor current is less than or equal to 80% of the rated AC drive current, the base value is the rated motor current.

— If the rated motor current is greater than 80% of the rated AC drive current, the base value is 80% of the rated AC drive current.

- P6-14 (Stop DC braking time)

This parameter specifies the holding time of DC braking. If it is set to 0, DC braking is cancelled.

The stop DC braking process is shown in the following figure.

Figure 6-14 Stop DC braking process

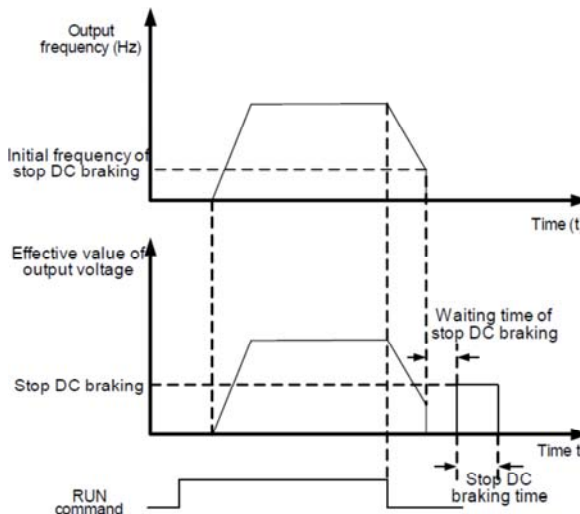



Function Code	Parameter Name	Setting Range	Default	Property
Group P6: Start/Stop Control				
P6-15	Brake use ratio	0%–100%	100%	☆

It is valid only for the AC drive with internal braking unit and used to adjust the duty ratio of the braking unit. The larger the value of this parameter is, the better the braking result will be. However, too larger value causes great fluctuation of the AC drive bus voltage during the braking process.

Group P7: Operation Panel and Display

Function Code	Parameter Name	Setting Range	Default	Property
Group P7: Operation Panel and Display				
P7-01	APP Key function selection	0:APP key disabled 1: Switchover between operation panel control and remote command control (terminal or communication) 2: Switchover between forward rotation and reverse rotation 3: Forward JOG 4: Reverse JOG	0	★

APP key refers to multifunctional key. You can set the function of the APP key by using this parameter. You can perform switchover by using this key both in stop or running state.

- 0: APP key disabled

This key is disabled.

- 1: Switchover between operation panel control and remote command control (terminal or communication)

You can perform switchover from the current command source to the operation panel control (local operation). If the current command source is operation panel control, this key is invalid.

- 2: Switchover between forward rotation and reverse rotation

You can change the direction of the frequency reference by using the APP key. It is valid only when the current command source is operation panel control.

- 3: Forward JOG

You can perform forward JOG (FJOG) by using the APP key.

- 4: Reverse JOG

You can perform reverse JOG (FJOG) by using the APP key.

Function Code	Parameter Name	Setting Range	Default	Property
Group P7: Operation Panel and Display				
P7-02	STOP/RESET key function	0: STOP/RESET key enabled only in operation panel control 1: STOP/RESET key enabled in any operation mode	1	☆

Function Code	Parameter Name	Setting Range	Default
Group P7: Operation Panel and Display			
P7-03	LED display running parameters 1	<p style="text-align: center;">0000–FFFF</p> <div style="display: flex; justify-content: space-around; border: 1px solid black; padding: 2px;"> 76543210 </div>	1F

If a parameter needs to be displayed during the running, set the corresponding bit to 1, and set P7-03 to the hexadecimal equivalent of this binary number.

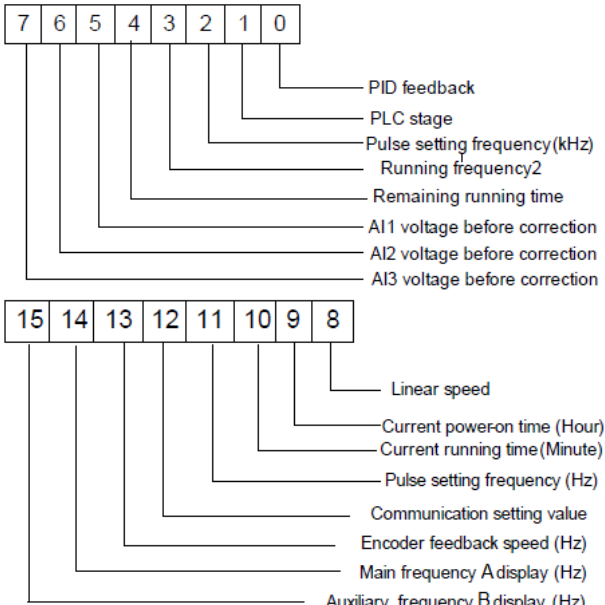
Function Code	Parameter Name	Setting Range	Default
Group P7: Operation Panel and Display			
P7-04	LED display running parameters 2	<p>0000–FFFF</p>  <p>If a parameter needs to be displayed during the running, set the corresponding bit to 1, and set P7-03 to the hexadecimal equivalent of this binary number.</p>	0

These two parameters are used to set the parameters that can be viewed when the AC drive is in the running state. You can view a maximum of 32 running state parameters that are displayed from the lowest bit of P7-03.

Function Code	Parameter Name	Setting Range	Default
Group P7: Operation Panel and Display			
P7-05	LED display stop parameters	0000–FFFF 	0
		If a parameter needs to be displayed during the running, set the corresponding bit to 1, and set P7-05 to the hexadecimal equivalent of this binary number.	

Function Code	Parameter Name	Setting Range	Default	Property
P7-06	Load speed display coefficient	0.0001–6.5000	1.0000	☆

This parameter is used to adjust the relationship between the output frequency of the AC drive and the load speed. For details, see the description of P7-12.

Function Code	Parameter Name	Setting Range	Default	Property
P7-07	Heatsink temperature of inverter module	0.0–100.0°C	--	●

It is used to display the insulated gate bipolar transistor (IGBT) temperature of the inverter module, and the IGBT overheat protection value of the inverter module depends on the model.

Function Code	Parameter Name	Setting Range	Default	Property
P7-08	Temporary software version	--	--	●

It is used to display the temporary software version of the control board.



Function Code	Parameter Name	Setting Range	Default	Property
Group P7: Operation Panel and Display				
P7-09	Accumulative running time	0-65535 h	--	●

It is used to display the accumulative running time of the AC drive. After the accumulative running time reaches the value set in P8-17, the terminal with the digital output function 12 becomes ON.

Function Code	Parameter Name	Setting Range	Default	Property
Group P7: Operation Panel and Display				
P7-10	Product number	--	--	●
P7-11	Software version	--	--	●
P7-12	Number of decimal places for load speed display	0: 0 decimal place 1: 1 decimal place 2: 2 decimal places 3: 3 decimal places	1	☆

P7-12 is used to set the number of decimal places for load speed display. The following gives an example to explain how to calculate the load speed:

Assume that P7-06 (Load speed display coefficient) is 2.000 and P7-12 is 2 (2 decimal places). When the running frequency of the AC drive is 40.00 Hz, the load speed is $40.00 \times 2.000 = 80.00$ (display of 2 decimal places).

If the AC drive is in the stop state, the load speed is the speed corresponding to the set frequency, namely, "set load speed". If the set frequency is 50.00 Hz, the load speed in the stop state is $50.00 \times 2.000 = 100.00$ (display of 2 decimal places).

Function Code	Parameter Name	Setting Range	Default	Property
Group P7: Operation Panel and Display				
P7-13	Accumulative power-on time	0-65535 h	0 h	●

It is used to display the accumulative power-on time of the AC drive since the delivery. If the time reaches the set power-on time (P8-17), the terminal with the digital output function 24 becomes ON.

Function Code	Parameter Name	Setting Range	Default	Property
Group P7: Operation Panel and Display				
P7-14	Accumulative power consumption	0-65535 kWh	--	●

It is used to display the accumulative power consumption of the AC drive until now.

Group F8: Auxiliary Functions

37

Function Code	Parameter Name	Setting Range	Default	Property
P8-00	JOG running frequency	0.00 Hz to maximum frequency	2.00 Hz	☆
P8-01	JOG acceleration time	0.0–6500.0s	20.0s	☆
P8-02	JOG deceleration time	0.0–6500.0s	20.0s	☆

These parameters are used to define the set frequency and acceleration/deceleration time of the AC drive when jogging. The startup mode is "Direct start" (P6-00 = 0) and the stop mode is "Decelerate to stop" (P6-10 = 0) during jogging.

Function Code	Parameter Name	Setting Range	Default	Property
Group P8: Auxiliary Functions				
P8-03	Acceleration time 2	0.0–6500.0s	Model dependent	☆
P8-04	Deceleration time 2	0.0–6500.0s		☆
P8-05	Acceleration time 3	0.0–6500.0s		☆
P8-06	Deceleration time 3	0.0–6500.0s		☆
P8-07	Acceleration time 4	0.0–6500.0s		☆
P8-08	Deceleration time 4	0.0–6500.0s		☆

The SSI700 provides a total of four groups of acceleration/deceleration time, that is, the preceding three groups and the group defined by P0-17 and P0-18. Definitions of four groups are completely the same. You can switch over between the four groups of acceleration/deceleration time through different state combinations of DI terminals. For more details, see the descriptions of P4-01 to P4-05.

Function Code	Parameter Name	Setting Range	Default
P8-09	Jump frequency 1	0.00 Hz to maximum frequency	0.00Hz
P8-10	Jump frequency 2	0.00 Hz to maximum frequency	0.00Hz
P8-11	Frequency jump amplitude	0.00 Hz to maximum frequency	0.00Hz

If the set frequency is within the frequency jump range, the actual running frequency is the jump frequency close to the set frequency. Setting the jump frequency helps to avoid the mechanical resonance point of the load.

The SSI700 supports two jump frequencies. If both are set to 0, the frequency jump function is disabled. The principle of the jump frequencies and jump amplitude is shown in the following figure.

Figure 6-15 Principle of the jump frequencies and jump amplitude

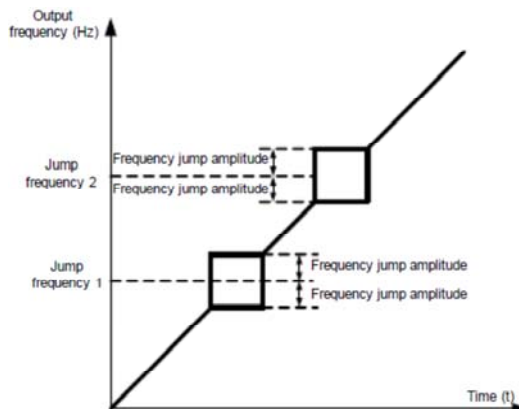

Function Code	Parameter Name	Setting Range	Default	Property
Group P8: Auxiliary Functions				
P8-12	Forward/Reverse rotation dead-zone time	0.0–3000.0s	0.0s	☆

It is used to set the time when the output is 0 Hz at transition of the AC drive forward rotation and reverse rotation, as shown in the following figure.

Figure 6-16 Forward/Reverse rotation dead-zone time

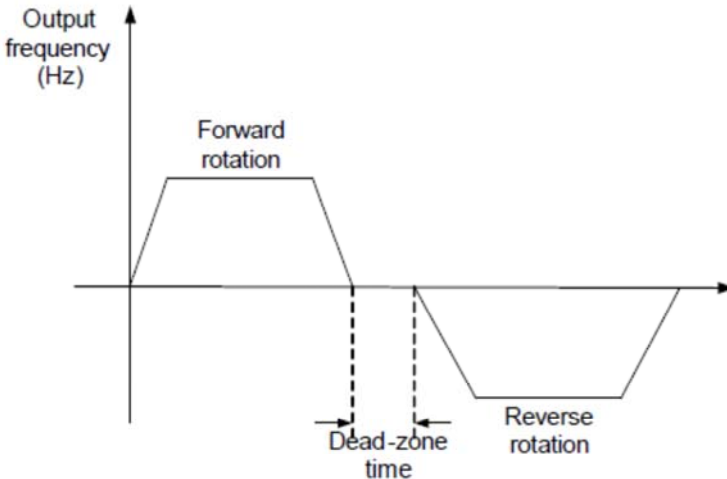

Function Code	Parameter Name	Setting Range	Default	Property
Group P8: Auxiliary Functions				
P8-13	Reverse control	0: Enabled 1: Disabled	0	☆

It is used to set whether the AC drive allows reverse rotation. In the applications where reverse rotation is prohibited, set this parameter to 1.

Function Code	Parameter Name	Setting Range	Default	Property
P8-14	Running mode when set frequency lower than frequency lower limit	0: Run at frequency lower limit 1: Stop 2: Run at zero speed	0	☆

It is used to set the AC drive running mode when the set frequency is lower than the frequency lower limit. The SSI700 provides three running modes to satisfy requirements of various applications.

Function Code	Parameter Name	Setting Range	Default	Property
P8-15	Droop control	0.00–10.00 Hz	0.00Hz	☆

This function is used for balancing the workload allocation when multiple motors are used to drive the same load. The output frequency of the AC drives decreases as the load increases. You can reduce the workload of the motor under load by decreasing the output frequency for this motor, implementing workload balancing between multiple motors.

Function Code	Parameter Name	Setting Range	Default	Property
P8-16	Accumulative power-on time	threshold 0–65000	0h	☆

If the accumulative power-on time (P7-13) reaches the value set in this parameter, the corresponding DO terminal becomes ON.

For example, combining virtual DI/DO functions, to implement the function that the AC drive reports an alarm when the actual accumulative power-on time reaches the threshold of 100 hours, perform the setting as follows:

1) Set the accumulative power-on time threshold to 100 h: P8-16 = 100 h.

Function Code	Parameter Name	Setting Range	Default	Property
Group P8: Auxiliary Functions				
P8-17	Accumulative running time	threshold 0–65000	0h	☆

It is used to set the accumulative running time threshold of the AC drive. If the accumulative running time (P7-09) reaches the value set in this parameter, the corresponding DO terminal becomes ON.

Function Code	Parameter Name	Setting Range	Default	Property
Group P8: Auxiliary Functions				
P8-18	Startup protection	0: No 1: Yes	0	☆

This parameter is used to set whether to enable the safety protection. If it is set to 1, the AC drive does not respond to the run command valid upon AC drive power-on (for example, an input terminal is ON before power-on). The AC drive responds only after the run command is cancelled and becomes valid again.

In addition, the AC drive does not respond to the run command valid upon fault reset of the AC drive. The run protection can be disabled only after the run command is cancelled.

In this way, the motor can be protected from responding to run commands upon power-on or fault reset in unexpected conditions.

Function Code	Parameter Name	Setting Range	Default	Property
Group P8: Auxiliary Functions				
P8-19	Frequency detection value (BRAKE control 1)	0.00 Hz to maximum frequency	50.00 Hz	☆
P8-20	Frequency detection hysteresis (BRAKE control hysteresis 1)	0.0%–100.0% (BRAKE control hysteresis 1)	5.0%	☆

If the running frequency is higher than the value of P8-19, the corresponding DO terminal becomes ON. If the running frequency is lower than value of P8-19, the DO terminal goes OFF

These two parameters are respectively used to set the detection value of output frequency and hysteresis value upon cancellation of the output. The value of P8-20 is a percentage of the hysteresis frequency to the frequency detection value (P8-19).

The BRAKE control function is shown in the following figure.



Figure 6-17 BRAKE control level

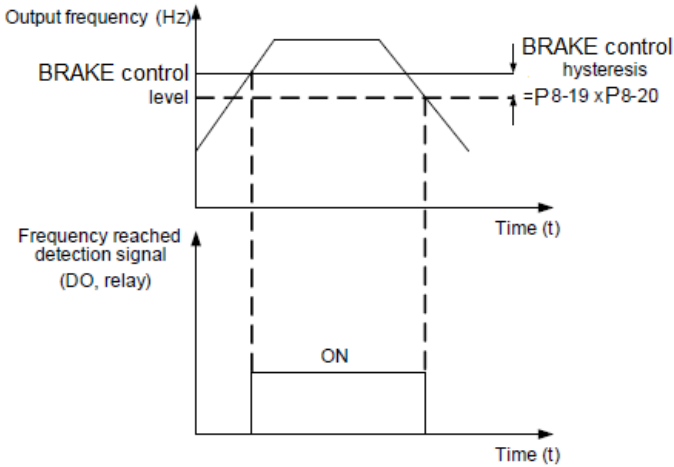

Function Code	Parameter Name	Setting Range	Default	Property
Group P8: Auxiliary Functions				
P8-21	Detection range of frequency reached	0.00–100% (maximum frequency)	0.0%	☆

If the AC drive running frequency is within the certain range of the set frequency, the corresponding DO terminal becomes ON.

This parameter is used to set the range within which the output frequency is detected to reach the set frequency. The value of this parameter is a percentage relative to the maximum frequency. The detection range of frequency reached is shown in the following figure.

Figure 6-18 Detection range of frequency reached

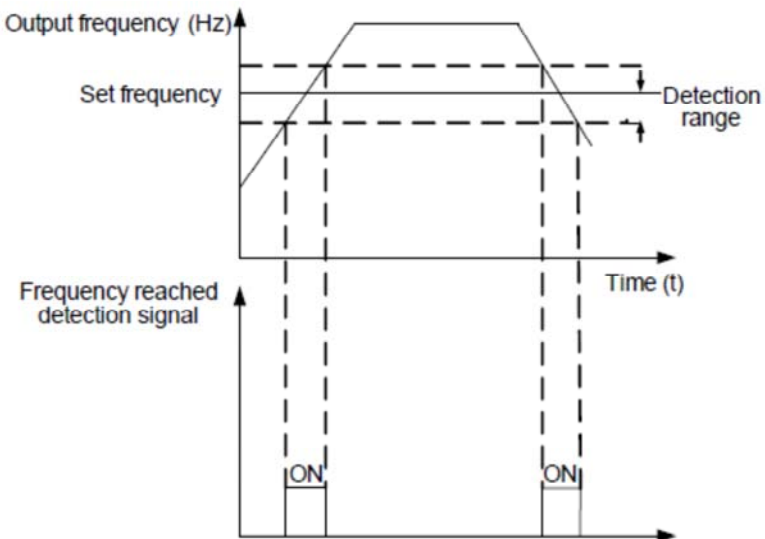



Function Code	Parameter Name	Setting Range	Default	Property
Group P8: Auxiliary Functions				
P8-22	Jump frequency during acceleration/deceleration	0: Disabled 1: Enabled	0	☆

It is used to set whether the jump frequencies are valid during acceleration/deceleration.

When the jump frequencies are valid during acceleration/deceleration, and the running frequency is within the frequency jump range, the actual running frequency will jump over the set frequency jump amplitude (rise directly from the lowest jump frequency to the highest jump frequency). The following figure shows the diagram when the jump frequencies are valid during acceleration/deceleration.

Figure 6-19 Diagram when the jump frequencies are valid during acceleration/deceleration

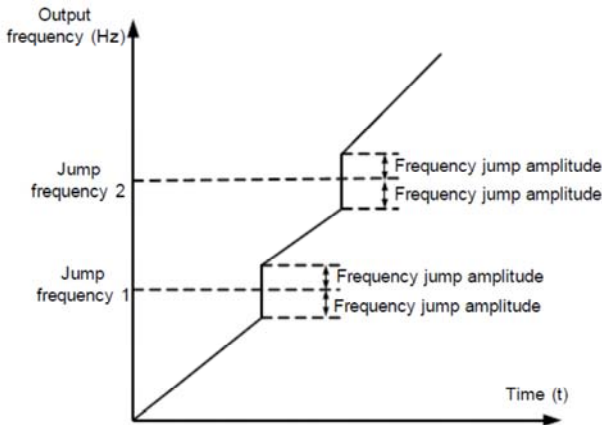

Function Code	Parameter Name	Setting Range	Default	Property
Group P8: Auxiliary Functions				
P8-25	Frequency switchover point between acceleration time 1 and acceleration time 2	0.00 to maximum frequency	0.00 Hz	☆
P8-26	Frequency switchover point between deceleration time 1 and deceleration time 2	0.00 to maximum frequency	0.00 Hz	☆

This function is valid when motor 1 is selected and acceleration/deceleration time switchover is not performed by means of DI terminal. It is used to select different groups of acceleration/deceleration time based on the running frequency range rather than DI terminal during the running process of the AC drive.

Figure 6-20 Acceleration/deceleration time switchover

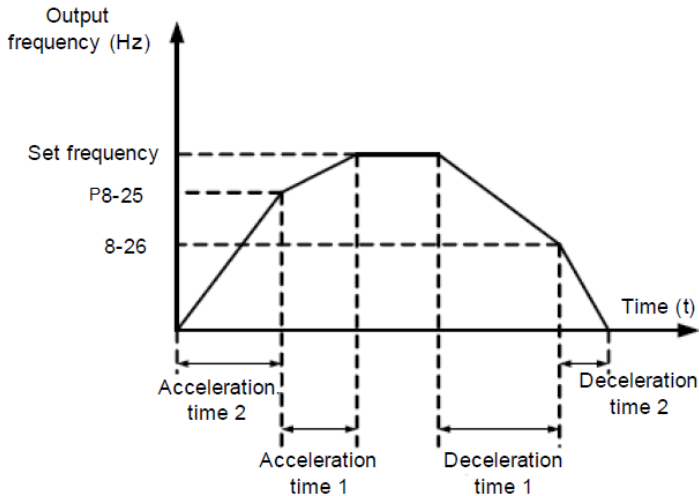

During acceleration, if the running frequency is smaller than the value of P8-25, acceleration time 2 is selected. If the running frequency is larger than the value of P8-25, acceleration time 1 is selected.

During deceleration, if the running frequency is larger than the value of P8-26, deceleration time 1 is selected. If the running frequency is smaller than the value of P8-26, deceleration time 2 is selected.

Function Code	Parameter Name	Setting Range	Default	Property
Group P8: Auxiliary Functions				
P8-27	Terminal JOG preferred	0: Disabled 1: Enabled	0	☆

It is used to set whether terminal JOG is preferred.

If terminal JOG is preferred, the AC drive switches to terminal JOG running state when there is a terminal JOG command during the running process of the AC drive.

Function Code	Parameter Name	Setting Range	Default	Property
Group P8: Auxiliary Functions				
P8-28	Frequency detection value (BRAKE control 2)	0.00 Hz to maximum frequency	50.00 Hz	☆
P8-29	Frequency detection hysteresis (BRAKE control hysteresis 2)	0.0%–100.0% (BRAKE control hysteresis 2)	5.0%	☆

The frequency detection function is the same as BRAKE control 1 function. For details, refer to the descriptions of P8-19 and P8-20.



Function Code	Parameter Name	Setting Range	Default	Property
Group P8: Auxiliary Functions				
P8-30	Any frequency reaching detection value 1	0.00 Hz to maximum frequency	50.00 Hz	☆
P8-31	Any frequency reaching detection amplitude 1	0.0%–100.0% (maximum frequency)	0.0%	☆
P8-32	Any frequency reaching detection value 2	0.00 Hz to maximum frequency	50.00 Hz	☆
P8-33	Any frequency reaching detection amplitude 2	0.0%–100.0% (maximum frequency)	0.0%	☆

If the output frequency of the AC drive is within the positive and negative amplitudes of the any frequency reaching detection value, the corresponding DO becomes ON.

The SSI700 provides two groups of any frequency reaching detection parameters, including frequency detection value and detection amplitude, as shown in the following figure.

Figure 6-21 Any frequency reaching detection

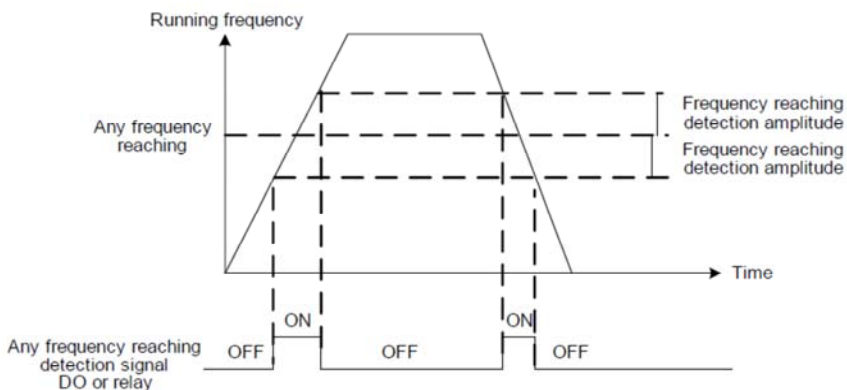

Function Code	Parameter Name	Setting Range	Default	Property
Group P8: Auxiliary Functions				
P8-34	Zero current detection level	0.0%–300.0% (rated motor current)	5.0%	☆
P8-35	Zero current detection delay time	0.00–600.00s	0.10s	☆

If the output current of the AC drive is equal to or less than the zero current detection level and the duration exceeds the zero current detection delay time, the corresponding DO becomes ON. The zero current detection is shown in the following figure.



Figure 6-22 Zero current detection

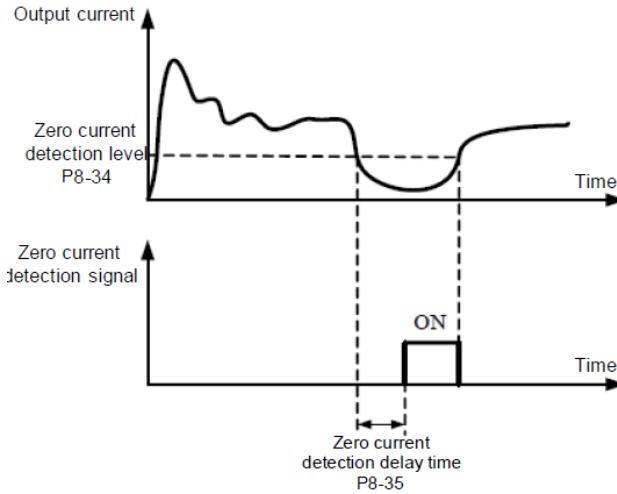

Function Code	Parameter Name	Setting Range	Default	Property
Group P8: Auxiliary Functions				
P8-36	Output overcurrent threshold	0.0% (no detection) 0.1%–300.0% (rated motor current)	200.0 %	☆
P8-37	Output overcurrent detection delay time	0.00–600.00s	0.00s	☆

If the output current of the AC drive is equal to or higher than the overcurrent threshold and the duration exceeds the detection delay time, the corresponding DO becomes ON. The output overcurrent detection function is shown in the following figure.

Figure 6-23 Output overcurrent detection

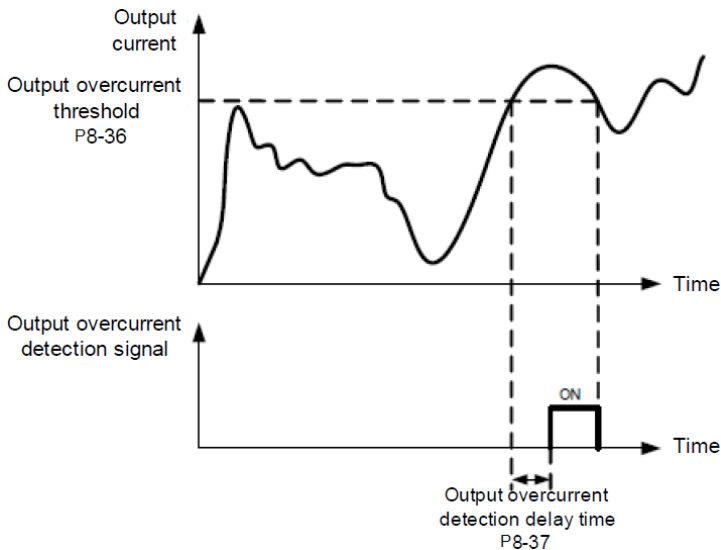



Function Code	Parameter Name	Setting Range	Default
P8-38	Any current reaching 1	0.0%–300.0% (rated motor current)	100.0%
P8-39	Any current reaching 1 amplitude	0.0%–300.0% (rated motor current)	0.0%
P8-40	Any current reaching 2	0.0%–300.0% (rated motor current)	100.0%
P8-41	Any current reaching 2 amplitude	0.0%–300.0% (rated motor current)	0.0%

If the output current of the AC drive is within the positive and negative amplitudes of any current reaching detection value, the corresponding DO becomes ON.

The SSI700 provides two groups of any current reaching detection parameters, including current detection value and detection amplitudes, as shown in the following figure.

Figure 6-24 Any current reaching detection

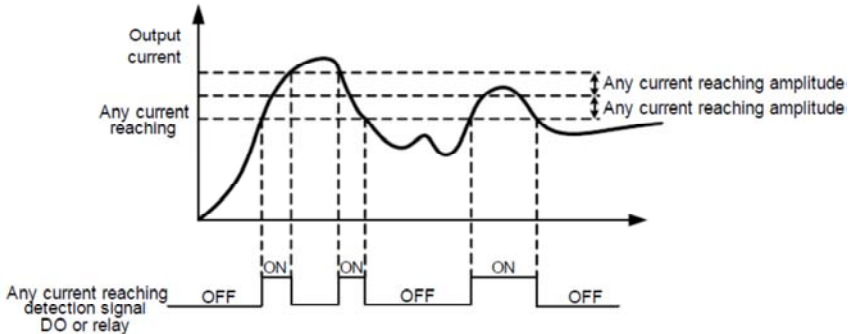

Function Code	Parameter Name	Setting Range	Default	Property
P8-42	Timing function	0: Disabled 1: Enabled	0	☆
P8-43	Timing duration source	0: P8-44 1: AI1 2: AI2 3: Resered(100%of analog input corresponds to the value of P8-44)	0	☆
P8-44	Timing duration	0.0–6500.0 min	0.0 min	☆

These parameters are used to implement the AC drive timing function.

If P8-42 is set to 1, the AC drive starts to time at startup. When the set timing duration is reached, the AC drive stops automatically and meanwhile the corresponding DO becomes ON.

The AC drive starts timing from 0 each time it starts up and the remaining timing duration can be queried by D0-20.

The timing duration is set in P8-43 and P8-44, in unit of minute.

Function Code	Parameter Name	Setting Range	Default	Property
P8-45	AI1 input voltage lower limit	0.00 V to P8-46	3.10V	☆
P8-46	AI1 input voltage upper limit	P8-45 to 10.00 V	6.80 V	☆

These two parameters are used to set the limits of the input voltage to provide protection on the AC drive. When the AI1 input is larger than the value of P8-46 or smaller than the value of P8-45, the corresponding DO becomes ON, indicating that AI1 input exceeds the limit.



Function Code	Parameter Name	Setting Range	Default	Property
Group P8: Auxiliary Functions				
P8-47	Module temperature threshold	0–100°C	75°C	☆

When the heatsink temperature of the AC drive reaches the value of this parameter, the corresponding DO becomes ON, indicating that the module temperature reaches the threshold.

Function Code	Parameter Name	Setting Range	Default	Property
Group P8: Auxiliary Functions				
P8-48	Cooling fan control	0: Fan working during running 1: Fan working continuously	0	☆

It is used to set the working mode of the cooling fan. If this parameter is set to 0, the fan works when the AC drive is in running state. When the AC drive stops, the cooling fan works if the heatsink temperature is higher than 40°C, and stops working if the heatsink temperature is lower than 40°C.

If this parameter is set to 1, the cooling fan keeps working after power-on.

Function Code	Parameter Name	Setting Range	Default	Property
Group P8: Auxiliary Functions				
P8-49	Wakeup frequency	Dormant frequency (P8-51) to maximum frequency (P0-10)	0.00Hz	☆
P8-50	Wakeup delay time	0.0–6500.0s	0.0s	☆
P8-51	Dormant(Sleeping) frequency	0.00 Hz to wakeup frequency (P8-49)	0.00Hz	☆
P8-52	Dormant(Sleeping) delay time	0.0–6500.0s	0.0s	☆

These parameters are used to implement the dormant and wakeup functions in the water supply application.

When the AC drive is in running state, the AC drive enters the dormant state and stops automatically after the dormant delay time (P8-52) if the set frequency is lower than or equal to the dormant frequency (P8-51).

When the AC drive is in dormant state and the current running command is effective, the AC drives starts up after the wakeup delay time (P8-50) if the set frequency is higher than or equal to the wakeup frequency (P8-49).

Generally, set the wakeup frequency equal to or higher than the dormant frequency. If the wakeup frequency and dormant frequency are set to 0, the dormant and wakeup functions are disabled.

When the dormant function is enabled, if the frequency source is PID, whether PID operation is performed in the dormant state is determined by 11-28. In this case, select PID operation enabled in the stop state (11-28 = 1).

Function Code	Parameter Name	Setting Range	Default	Property
Group P8: Auxiliary Functions				
P8-53	Current running time reached	0.0–6500.0 min	0.0 min	☆

If the current running time reaches the value set in this parameter, the corresponding DO becomes ON, indicating that the current running time is reached.

Group F9: Fault and Protection

47

Function Code	Parameter Name	Setting Range	Default	Property
P9-00	Motor overload protection selection	0: Disabled 1: Enabled	1	☆
P9-01	Motor overload protection gain	0.20–10.00	1.00	☆

- P9-00 = 0

The motor overload protective function is disabled. The motor is exposed to potential damage due to overheating. A thermal relay is suggested to be installed between the AC drive and the motor.

- P9-00 = 1

The AC drive judges whether the motor is overloaded according to the inverse time-lag curve of the motor overload protection.

The inverse time-lag curve of the motor overload protection is:

$220\% \times P9-01 \times \text{rated motor current}$ (if the load remains at this value for one minute, the AC drive reports motor overload fault), or

$150\% \times P9-01 \times \text{rated motor current}$ (if the load remains at this value for 60 minutes, the AC drive reports motor overload fault)

Set P9-01 properly based on the actual overload capacity. If the value of P9-01 is set too large, damage to the motor may result because the motor overheats but the AC drive does not report the alarm.

Function Code	Parameter Name	Setting Range	Default	Property
P9-02	Motor overload warning coefficient	50%–100%	80%	☆

This function is used to give a warning signal to the control system via DO before motor overload protection. This parameter is used to determine the percentage, at which prewarning is performed before motor overload. The larger the value is, the less advanced the pre-warning will be.

When the accumulative output current of the AC drive is greater than the value of the overload inverse time-lag curve multiplied by P9-02, the DO terminal on the AC drive allocated with function 6 (Motor overload pre-warning) becomes ON.

Function Code	Parameter Name	Setting Range	Default	Property
P9-03	Overvoltage stall gain	0 (no stall overvoltage)–100	0	☆
P9-04	Overvoltage stall protective voltage	120%–150%	130%	☆

When the DC bus voltage exceeds the value of P9-04 (Overvoltage stall protective voltage) during deceleration of the AC drive, the AC drive stops deceleration and keeps the present running frequency. After the bus voltage declines, the AC drive continues to decelerate.

P9-03 (Overvoltage stall gain) is used to adjust the overvoltage suppression capacity of the AC drive. The larger the value is, the greater the overvoltage suppression capacity will be.

In the prerequisite of no overvoltage occurrence, set P9-03 to a small value.

For small-inertia load, the value should be small. Otherwise, the system dynamic response will be slow. For large-inertia load, the value should be large. Otherwise, the suppression result will be poor and an overvoltage fault may occur. If the overvoltage stall

gain is set to 0, the overvoltage stall function is disabled. The overvoltage stall protective voltage setting 100% corresponds to the base values in the following table:

Table 6-7 Overvoltage stall protective voltage setting 100% corresponds to base values

Voltage Class	Corresponding Base Value
Single-phase 220 V	290 V
Three-phase 220 V	290 V
Three-phase 380 V	530 V

Function Code	Parameter Name	Setting Range	Default	Property
P9-05	Overcurrent stall gain	0–100	20	☆
P9-06	Overcurrent stall protective current	100%–200%	150%	☆
P9-07	Short-circuit to ground upon power-on	0: Disabled 1: Enabled	1	☆
P9-09	Fault auto reset times	0–20	0	☆
P9-10	DO action during fault auto reset	0: Not act 1: Act	0	☆
P9-11	Time interval of fault auto reset	0.1s–100.0s	1.0s	☆

When the output current exceeds the overcurrent stall protective current during acceleration/deceleration of the AC drive, the AC drive stops acceleration/deceleration and keeps the present running frequency. After the output current declines, the AC drive continues to accelerate/decelerate.

P9-05 (Overcurrent stall gain) is used to adjust the overcurrent suppression capacity of the AC drive. The larger the value is, the greater the overcurrent suppression capacity will be. In the prerequisite of no overcurrent occurrence, set P9-05 to a small value.

For small-inertia load, the value should be small. Otherwise, the system dynamic response will be slow. For large-inertia load, the value should be large. Otherwise, the suppression result will be poor and overcurrent fault may occur.

If the overcurrent stall gain is set to 0, the overcurrent stall function is disabled.

Figure 6-25 Diagram of the overcurrent stall protection function

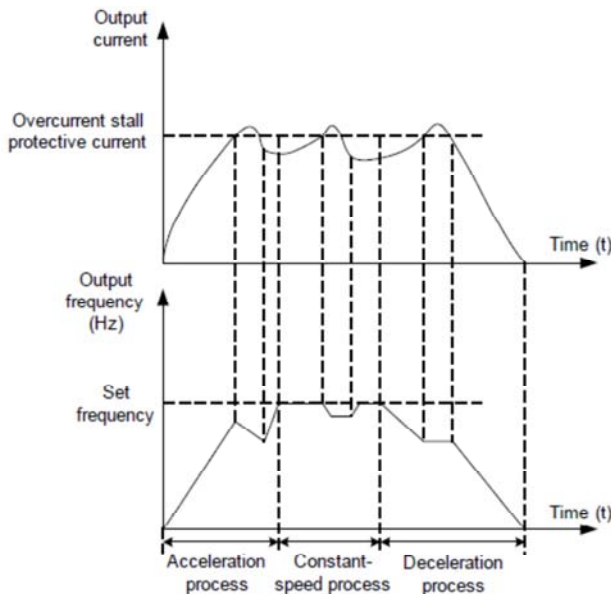

Function Code	Parameter Name	Setting Range	Default	Property
P9-07	Short-circuit to ground upon power-on	0: Disabled 1: Enabled	1	☆

It is used to determine whether to check the motor is short-circuited to ground at power-on of the AC drive. If this function is enabled, the AC drive's UVW will have voltage output a while after power-on.

Function Code	Parameter Name	Setting Range	Default	Property
P9-09	Fault auto reset times	0–20	0	☆

It is used to set the times of fault auto resets if this function is used. After the value is exceeded, the AC drive will remain in the fault state.

Function Code	Parameter Name	Setting Range	Default	Property
P9-10	DO action during fault auto reset	0: Not act 1: Act	0	☆

It is used to decide whether the DO acts during the fault auto reset if the fault auto reset function is selected.

Function Code	Parameter Name	Setting Range	Default	Property
P9-11	Time interval of fault auto reset	0.1s–100.0s	1.0s	☆

It is used to set the waiting time from the alarm of the AC drive to fault auto reset.

Function Code	Parameter Name	Setting Range	Default	Property
P9-12	Input phase loss protection/ contactor energizing protection selection	Unit's digit: Input phase loss protection Ten's digit: Contactor energizing protection 0: Disabled 1: Enabled	11	☆

It is used to determine whether to perform input phase loss or contactor energizing protection.

The SSI700 models that provide this function are listed .

For every voltage class, the SSI700 AC drives of powers equal to or greater than those listed in the preceding table provide the function of input phase loss or contactor energizing protection. The SSI700 AC drives below the power listed in the table do not have the function no matter whether P9-12 is set to 0 or 1.

Function Code	Parameter Name	Setting Range	Default	Property
P9-13	Output phase loss protection selection	0: Disabled 1: Enabled	1	☆

It is used to determine whether to perform output phase loss protection.

Function Code	Parameter Name	Setting Range
P9-14	1st fault type	0~99
P9-15	2nd fault type	
P9-16	3rd (latest) fault type	

It is used to record the types of the most recent three faults of the AC drive. 0 indicates no fault. For possible causes and solution of each fault, refer to Chapter 8.

Function Code	Parameter Name	Description																				
P9-17	Frequency upon 3 rd fault	It displays the frequency when the latest fault occurs.																				
P9-18	Current upon 3 rd fault	It displays the current when the latest fault occurs.																				
P9-19	Bus voltage upon 3 rd fault	It displays the bus voltage when the latest fault occurs																				
P9-20	DI status upon 3 rd fault	<p>It displays the status of all DI terminals when the latest fault occurs.</p> <p>The sequence is as follows:</p> <table border="1" style="margin-left: auto; margin-right: auto;"> <tr> <td>BIT9</td><td>BIT8</td><td>BIT7</td><td>BIT6</td><td>BIT5</td><td>BIT4</td><td>BIT3</td><td>BIT2</td><td>BIT1</td><td>BIT0</td> </tr> <tr> <td>DI0</td><td>DI9</td><td>DI8</td><td>DI7</td><td>DI6</td><td>DI5</td><td>DI4</td><td>DI3</td><td>DI2</td><td>DI1</td> </tr> </table> <p>If a DI is ON, the setting is 1. If the DI is OFF, the setting is 0. The value is the equivalent decimal number converted from the DI status..</p>	BIT9	BIT8	BIT7	BIT6	BIT5	BIT4	BIT3	BIT2	BIT1	BIT0	DI0	DI9	DI8	DI7	DI6	DI5	DI4	DI3	DI2	DI1
BIT9	BIT8	BIT7	BIT6	BIT5	BIT4	BIT3	BIT2	BIT1	BIT0													
DI0	DI9	DI8	DI7	DI6	DI5	DI4	DI3	DI2	DI1													
P9-21	Output terminal status upon 3 rd fault	<p>It displays the status of all output terminals when the latest fault occurs.</p> <p>The sequence is as follows:</p> <table border="1" style="margin-left: auto; margin-right: auto;"> <tr> <td>BIT4</td><td>BIT3</td><td>BIT2</td><td>BIT1</td><td>BIT0</td> </tr> <tr> <td>DO2</td><td>DO1</td><td>REL2</td><td>REL1</td><td>FMP</td> </tr> </table> <p>If an output terminal is ON, the setting is 1. If the output terminal is OFF, the setting is 0. The value is the equivalent decimal number converted from the DI statuses</p>	BIT4	BIT3	BIT2	BIT1	BIT0	DO2	DO1	REL2	REL1	FMP										
BIT4	BIT3	BIT2	BIT1	BIT0																		
DO2	DO1	REL2	REL1	FMP																		
P9-22	AC drive status upon 3 rd fault	-																				
P9-23	Power-on time upon 3 rd fault	It displays the present power-on time when the latest fault occurs.																				
P9-24	Running time upon 3 rd fault	It displays the present running time when the latest fault occurs.																				
P9-27	Frequency upon 2 nd fault	Same as P9-17–P9-24.																				
P9-28	Current upon 2 nd fault																					
P9-29	Bus voltage upon 2 nd fault																					
P9-30	DI status upon 2 nd fault																					
P9-31	Output terminal status upon 2 nd fault																					
P9-32	AC drive status upon 2 nd fault																					
P9-33	Power-on time upon 2 nd fault																					
P9-34	Running time upon 2 nd fault	Same as P9-17–P9-24.																				
P9-37	Frequency upon 2 nd fault																					
P9-38	Current upon 1 nd fault																					
P9-39	Bus voltage upon 1 nd fault																					
P9-40	DI status upon 1 nd fault																					
P9-41	Output terminal status upon 1 nd fault																					
P9-42	AC drive status upon 1 rd fault																					
P9-43	Power-on time upon 1 rd fault																					
P9-44	Running time upon 1 rd fault																					



Function Code	Parameter Name	Setting Range	Default
Group 9: Fault and Protection			
P9-47	Fault protection action selection 1	Unit's digit (Motor overload, OL1)	00000
		0: Coast to stop 1: Stop according to the stop mode 2: Continue to run	
		Hundred's digit (Power output phase loss, LF)	
		Same as unit's digit	
		Thousand's digit (External equipment fault, EF)	
		Same as unit's digit	
		Ten thousand's digit (Communication fault, CE)	
P9-48	Fault protection action selection 2	Ten's digit (EEPROM read-write fault, EP)	00000
		0: Coast to stop 1: Stop according to the stop Mode	
		Ten thousand's digit (Accumulative running time reached)	
		Same as unit's digit in P9-47	
P9-49	Fault protection action selection 3	Hundred's digit (Accumulative power-on time reached, UT)	00000
		Same as unit's digit in P9-47	
		Thousand's digit (Load becoming 0)	
		0: Coast to stop 1: Stop according to the stop mode 2: Continue to run at 7% of rated motor frequency and resume to the set frequency if the load recovers	
		Ten thousand's digit (PID feedback lost during running, PD)	
		Same as unit's digit in P9-47	
P9-50	Fault protection action selection 4	Unit's digit (Too large speed deviation)	00000
		Same as unit's digit in P9-47	
		Ten's digit (Motor over-speed)	
		Same as unit's digit in P9-47	
		Hundred's digit (Initial position fault)	
		Same as unit's digit in P9-47	

If "Coast to stop" is selected, the AC drive displays fault and directly stops.

- If "Stop according to the stop mode" is selected, the AC drive displays D** and stops according to the stop mode. After stop, the AC drive displays fault.
- If "Continue to run" is selected, the AC drive continues to run and displays D**. The running frequency is set in P9-54.

Function Code	Parameter Name	Setting Range	Default
P9-54	Frequency selection for continuing to run upon fault	0: Current running frequency 1: Set frequency 2: Frequency upper limit 3: Frequency lower limit 4: Backup frequency upon abnormality	0
P9-55	Backup frequency upon abnormality	0.0%–100.0% (maximum frequency)	100.0%

If a fault occurs during the running of the AC drive and the handling of fault is set to "Continue to run", the AC drive displays D** and continues to run at the frequency set in P9-54.

The setting of P9-55 is a percentage relative to the maximum frequency.



Function Code	Parameter Name	Setting Range	Default	Property
Group 9: Fault and Protection				
P9-59	Action selection at instantaneous power failure	0: Invalid 1: Decelerate 2: Decelerate to stop	0	☆
P9-60	Action pause judging voltage at instantaneous power failure	80.0%–100.0%	90.0%	☆
P9-61	Voltage rally judging time at instantaneous power failure	0.00–100.00s	0.50s	☆
P9-62	Action judging voltage at instantaneous power failure	60.0%–100.0% (standard bus voltage)	80.0%	☆

Upon instantaneous power failure or sudden voltage dip, the DC bus voltage of the AC drive reduces. This function enables the AC drive to compensate the DC bus voltage reduction with the load feedback energy by reducing the output frequency so as to keep the AC drive running continuously.

- If P9-59 = 1, upon instantaneous power failure or sudden voltage dip, the AC drive decelerates. Once the bus voltage resumes to normal, the AC drive accelerates to the set frequency. If the bus voltage remains normal for the time exceeding the value set in P9-61, it is considered that the bus voltage resumes to normal.
- If P9-59 = 2, upon instantaneous power failure or sudden voltage dip, the AC drive decelerates to stop.

Figure 6-26 AC drive action diagram upon instantaneous power failure

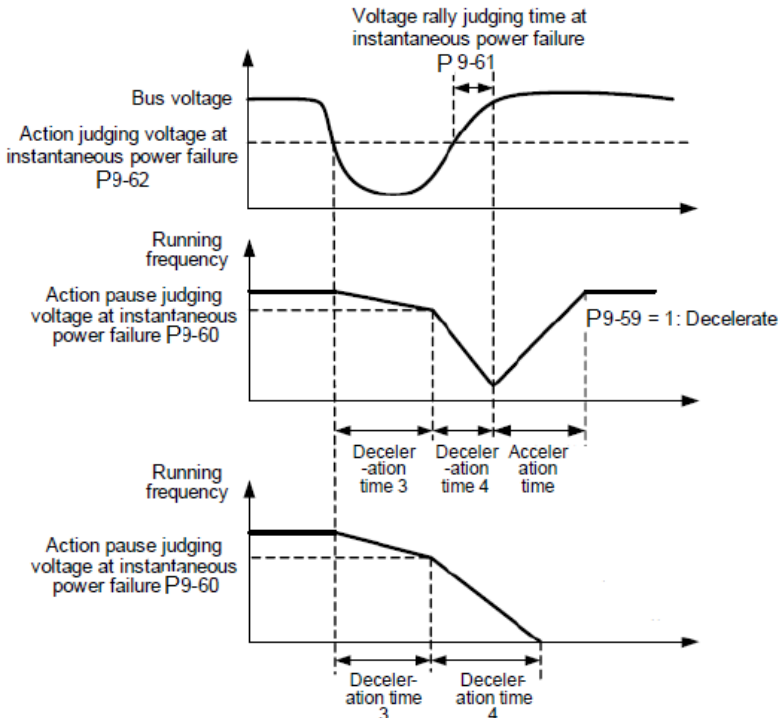



Function Code	Parameter Name	Setting Range	Default	Property
Group 9: Fault and Protection				
P9-63	Protection upon load becoming 0	0: Disabled 1: Enabled	0	☆
P9-64	Detection level of load becoming 0	0.0%–100.0% (rated motor current)	10.0%	☆
P9-65	Detection time of load becoming 0	0 0.0–60.0s	1.0s	☆

If protection upon load becoming 0 is enabled, when the output current of the AC drive is lower than the detection level (P9-64) and the lasting time exceeds the detection time (P9-65), the output frequency of the AC drive automatically declines to 7% of the rated frequency. During the protection, the AC drive automatically accelerates to the set frequency if the load resumes to normal.

Group 10: Process Control PID Function

PID control is a general process control method. By performing proportional, integral and differential operations on the difference between the feedback signal and the target signal, it adjusts the output frequency and constitutes a feedback system to stabilize the controlled counter around the target value.

It is applied to process control such as flow control, pressure control and temperature control. The following figure shows the principle block diagram of PID control.

Figure 6-27 Principle block diagram of PID control

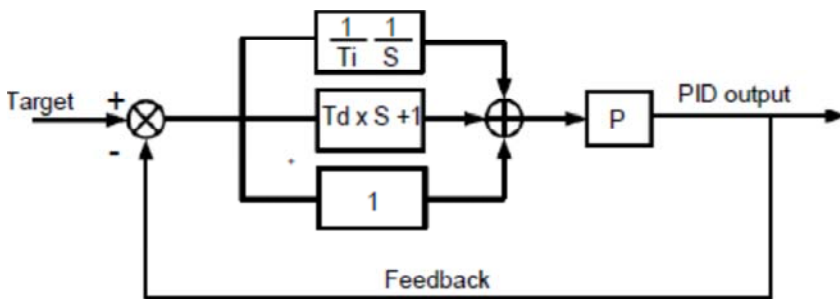

Function Code	Parameter Name	Setting Range	Default	Property
Group 10: Process Control PID Function				
10-00	PID setting source	0: 10-01 1: AI1 2: AI2 3: Reserved 4: Pulse setting (DI5) 5: Communication setting 6: Multi-reference	0	☆
10-01	PID digital setting	0.0%–100.0%	50.0%	☆

10-00 is used to select the channel of target process PID setting. The PID setting is a relative value and ranges from 0.0% to 100.0%. The PID feedback is also a relative value. The purpose of PID control is to make the PID setting and PID feedback equal.



Function Code	Parameter Name	Setting Range	Default	Property
Group 10: Process Control PID Function				
10-02	PID feedback source	0: AI1 1: AI2 2: Reserved 3: AI1 – AI2 4: Pulse setting (DI5) 5: Communication setting 6: AI1 + AI2 7: MAX (AI1 , AI2) 8: MIN (AI1 , AI2)	0	☆

This parameter is used to select the feedback signal channel of process PID.

The PID feedback is a relative value and ranges from 0.0% to 100.0%.

Function Code	Parameter Name	Setting Range	Default	Property
Group 10: Process Control PID Function				
10-03	PID action direction	0: Forward action 1: Reverse action	0	☆

- 0: Forward action

When the feedback value is smaller than the PID setting, the AC drive's output frequency rises. For example, the winding tension control requires forward PID action.

- 1: Reverse action

When the feedback value is smaller than the PID setting, the AC drive's output frequency reduces. For example, the unwinding tension control requires reverse PID action.

Notes				
that this function is influenced by the DI function 35 "Reverse PID action direction".				

Function Code	Parameter Name	Setting Range	Default	Property
10-04	PID setting feedback range	0–65535	1000	☆

This parameter is a non-dimensional unit. It is used for PID setting display (D0-15) and PID feedback display (D0-16).

Relative value 100% of PID setting feedback corresponds to the value of 10-04. If 10-04 is set to 2000 and PID setting is 100.0%, the PID setting display (D0-15) is 2000.

Function Code	Parameter Name	Setting Range	Default	Property
10-05	Proportional gain Kp1	0.0–100.0	20.0	☆
10-06	Integral time Ti1	0.01–10.00s	2.00s	☆
10-07	Differential time Td1	0.00–10.000	0.000s	☆

- 10-05 (Proportional gain Kp1)

It decides the regulating intensity of the PID regulator. The higher the Kp1 is, the larger the regulating intensity is. The value 100.0 indicates when the deviation between PID feedback and PID setting is 100.0%, the adjustment amplitude of the PID regulator on the output frequency reference is the maximum frequency.

- 10-06 (Integral time Ti1)

It decides the integral regulating intensity. The shorter the integral time is, the larger the regulating intensity is. When the deviation between PID feedback and PID setting is 100.0%, the integral regulator performs continuous adjustment for the time set in 10-06. Then the adjustment amplitude reaches the maximum frequency.

- 10-07 (Differential time Td1)

It decides the regulating intensity of the PID regulator on the deviation change. The longer the differential time is, the larger the regulating intensity is. Differential time is the time within which the feedback value change reaches 100.0%, and then the adjustment amplitude reaches the maximum frequency.

Function Code	Parameter Name	Setting Range	Default	Property
Group 10: Process Control PID Function				
10-08	Cut-off frequency of PID reverse rotation	0.00 to maximum frequency	2.00 Hz	☆

In some situations, only when the PID output frequency is a negative value (AC drive reverse rotation), PID setting and PID feedback can be equal. However, too high reverse rotation frequency is prohibited in some applications, and 10-08 is used to determine the reverse rotation frequency upper limit.

Function Code	Parameter Name	Setting Range	Default	Property
Group 10: Process Control PID Function				
10-09	PID deviation limit	0.0%–100.0%	0.0%	☆

If the deviation between PID feedback and PID setting is smaller than the value of 10-09, PID control stops. The small deviation between PID feedback and PID setting will make the output frequency stabilize, effective for control applications.

Function Code	Parameter Name	Setting Range	Default	Property
Group 10: Process Control PID Function				
10-10	PID differential limit	0.00%–100.00%	0.10%	☆

It is used to set the PID differential output range. In PID control, the differential operation may easily cause system oscillation. Thus, the PID differential regulation is restricted to a small range.

Function Code	Parameter Name	Setting Range	Default	Property
Group 10: Process Control PID Function				
10-11	PID setting change time	0.00–650.00s	0.00s	☆

The PID setting change time indicates the time required for PID setting changing from 0.0% to 100.0%. The PID setting changes linearly according to the change time, reducing the impact caused by sudden setting change on the system.

Function Code	Parameter Name	Setting Range	Default	Property
Group 10: Process Control PID Function				
10-12	PID feedback filter time	0.00–60.00s	0.00s	☆
10-13	PID output filter time	0.00–60.00s	0.00s	☆

10-12 is used to filter the PID feedback, helping to reduce interference on the feedback but slowing the response of the process system.

10-13 is used to filter the PID output frequency, helping to weaken sudden change of the AC drive output frequency but slowing the response of the process system.



Function Code	Parameter Name	Setting Range	Default	Property
Group 10: Process Control PID Function				
10-15	Proportional gain Kp2	0.0–100.0	20.0	☆
10-16	Integral time Ti2	0.0–100.0	20.0	☆
10-17	Differential time Td2	0.000–10.000s	0.000s	☆
10-18	PID parameter switchover condition	0: No switchover 1: Switchover via DI 2: Automatic switchover based on deviation	0	☆
10-19	PID parameter switchover deviation 1	0.0% to 10-20	20.0%	☆
10-20	PID parameter switchover deviation 2	10-19 to 100.0%	80.0%	☆

In some applications, PID parameters switchover is required when one group of PID parameters cannot satisfy the requirement of the whole running process.

These parameters are used for switchover between two groups of PID parameters. Regulator parameters 10-15 to 10-17 are set in the same way as 10-05 to 10-07.

The switchover can be implemented either via a DI terminal or automatically implemented based on the deviation.

If you select switchover via a DI terminal, the DI must be allocated with function 43 "PID parameter switchover". If the DI is OFF, group 1 (10-05 to 10-07) is selected. If the DI is ON, group 2 (10-15 to 10-17) is selected.

If you select automatic switchover, when the absolute value of the deviation between PID feedback and PID setting is smaller than the value of 10-19, group1 is selected. When the absolute value of the deviation between PID feedback and PID setting is higher than the value of 10-20, group 2 is selected. When the deviation is between 10-19 and 10-20, the PID parameters are the linear interpolated value of the two groups of parameter values.

Figure 6-28 PID parameters switchover

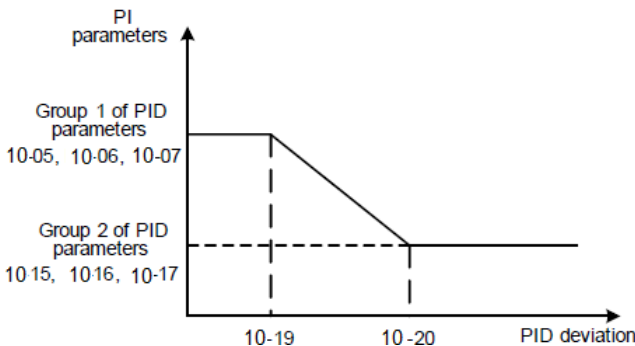

Function Code	Parameter Name	Setting Range	Default	Property
Group 10: Process Control PID Function				
10-21	PID initial value	0.0%–100.0%	0.0%	☆
10-22	PID initial value holding time	0.00–650.00s	0.00s	☆

When the AC drive starts up, the PID starts algorithm only after the PID output is fixed to the PID initial value (10-21) and lasts the time set in 10-22.

Figure 6-29 PID initial value function

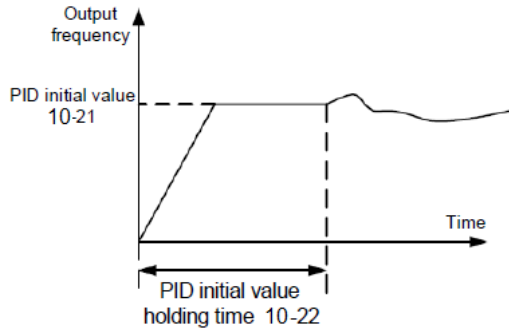

Function Code	Parameter Name	Setting Range	Default	Property
10-23	Maximum deviation between two PID outputs in forward direction	0.00%–100.00%	1.00%	☆
10-24	Maximum deviation between two PID outputs in reverse direction	0.00%–100.00%	1.00%	☆

This function is used to limit the deviation between two PID outputs (2 ms per PID output) to suppress the rapid change of PID output and stabilize the running of the AC drive.

10-23 and 10-24 respectively correspond to the maximum absolute value of the output deviation in forward direction and in reverse direction.

Function Code	Parameter Name	Setting Range	Default
10-25	PID integral property	Unit's digit (Integral separated)	00
		0: Invalid 1: Valid	
		Ten's digit (Whether to stop integral operation when the output reaches the limit)	
		0: Continue integral operation 1: Stop integral operation	

- Integral separated

If it is set to valid, , the PID integral operation stops when the DI allocated with function 38 "PID integral pause" is ON In this case, only proportional and differential operations take effect.

If it is set to invalid, integral separated remains invalid no matter whether the DI allocated with function 38 "PID integral pause" is ON or not.

- Whether to stop integral operation when the output reaches the limit

If "Stop integral operation" is selected, the PID integral operation stops, which may help to reduce the PID overshoot.

Function Code	Parameter Name	Setting Range	Default	Property
10-26	PID operation at stop	0: No PID operation at stop 1: PID operation at stop	0	☆

It is used to select whether to continue PID operation in the state of stop. Generally, the PID operation stops when the AC drive stops.

Function Code	Parameter Name	Setting Range	Default
10-28	Detection value of PID feedback loss	0.0%: Not judging feedback loss 0.1%–100.0%	0.0%
10-27	Detection time of PID feedback loss	0.0–20.0s	0.0s



These parameters are used to judge whether PID feedback is lost.

If the PID feedback is smaller than the value of 10-28 and the lasting time exceeds the value of 10-27, the AC drive reports fault PD and acts according to the selected fault protection action.

Group 11: Swing Frequency, Fixed Length and Count

The swing frequency function is applied to the textile and chemical fiber fields and the applications where traversing and winding functions are required.

The swing frequency function indicates that the output frequency of the AC drive swings up and down with the set frequency as the center. The trace of running frequency at the time axis is shown in the following figure.

The swing amplitude is set in 11-00 and 11-01. When 11-01 is set to 0, the swing amplitude is 0 and the swing frequency does not take effect.

Figure 6-30 Swing frequency control

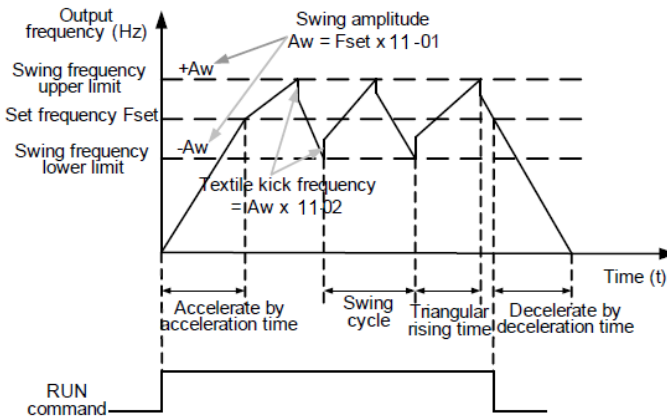

Function Code	Parameter Name	Setting Range	Default	Property
11-00	Swing frequency setting mode	0: Relative to the central frequency 1: Relative to the maximum frequency	0	☆

This parameter is used to select the base value of the swing amplitude.

- 0: Relative to the central frequency (P0-07 frequency source selection)

It is variable swing amplitude system. The swing amplitude varies with the central frequency (set frequency).

- 1: Relative to the maximum frequency (P0-10 maximum output frequency)

It is fixed swing amplitude system. The swing amplitude is fixed.

Function Code	Parameter Name	Setting Range	Default	Property
11-01	Swing frequency amplitude	0.0%–100.0%	0.0%	☆
11-02	Jump frequency amplitude	0.0%–50.0%	0.0%	☆

This parameter is used to determine the swing amplitude and jump frequency amplitude. The swing frequency is limited by the frequency upper limit and frequency lower limit.

- If relative to the central frequency (11-00 = 0), the actual swing amplitude AW is the calculation result of P0-07 (Frequency source selection) multiplied by 11-01.

- If relative to the maximum frequency (11-00 = 1), the actual swing amplitude AW is the calculation result of P0-10 (Maximum frequency) multiplied by 11-01.

Jump frequency = Swing amplitude AW x 11-02 (Jump frequency amplitude).

- If relative to the central frequency (11-00 = 0), the jump frequency is a variable value.

- If relative to the maximum frequency (11-00 = 1), the jump frequency is a fixed value.

The swing frequency is limited by the frequency upper limit and frequency lower limit.

Function Code	Parameter Name	Setting Range	Default	Property
11-03	Swing frequency cycle	0.0–3000.0s	10.0s	☆
11-04	Triangular wave rising timecoefficient	0.0%–100.0%	50.0%	☆

11-03 specifies the time of a complete swing frequency cycle.

11-04 specifies the time percentage of triangular wave rising time to 11-03 (Swing frequency cycle).

- Triangular wave rising time = 11-03 (Swing frequency cycle) x 11-04 (Triangular wave rising time coefficient, unit: s)

- Triangular wave falling time = 11-03 (Swing frequency cycle) x (1 – 11-04 Triangular wave rising time coefficient ,unit: s)

Function Code	Parameter Name	Setting Range	Default	Property
11-05	Set length	0–65535 m	1000m	☆
11-06	Actual length	0–65535 m	0 m	☆
11-07	Number of pulses per meter	0.1–6553.5	100.0	☆

The preceding parameters are used for fixed length control.

The length information is collected by DI terminals. 11-06 (Actual length) is calculated by dividing the number of pulses collected by the DI terminal by 11-07 (Number of pulses each meter).

When the actual length 11-06 exceeds the set length in 11-05, the DO terminal allocated with function 10 (Length reached) becomes ON.

During the fixed length control, the length reset operation can be performed via the DI terminal allocated with function 28. For details, see the descriptions of P4-00 to P4-09.

Allocate corresponding DI terminal with function 27 (Length count input) in applications. If the pulse frequency is high, DI5 must be used.

Function Code	Parameter Name	Setting Range	Default	Property
11-08	Set count value	1–65535	1000	☆
11-09	Designated count value	1–65535	1000	☆

The count value needs to be collected by DI terminal. Allocate the corresponding DI terminal with function 25 (Counter input) in applications. If the pulse frequency is high, DI5 must be used.

When the count value reaches the set count value (11-08), the DO terminal allocated with function 8 (Set count value reached) becomes ON. Then the counter stops counting.

When the counting value reaches the designated counting value (11-09), the DO terminal allocated with function 9 (Designated count value reached) becomes ON. Then the counter continues to count until the set count value is reached.

11-09 should be equal to or smaller than 11-08.

Figure 6-31 Reaching the set count value and designated count value

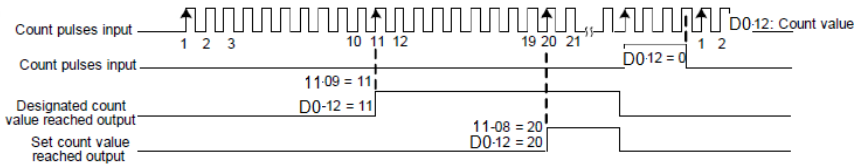

Group 12: Multi-Reference and Simple PLC Function

The SSI700 multi-reference has many functions. Besides multi-speed, it can be used as the setting source of the V/F separated voltage source and setting source of process PID. In addition, the multi-reference is relative value.

The simple PLC function is different from the SSI700 user programmable function. Simple PLC can only complete simple combination of multi-reference, while the user programmable function is more practical.

Function Code	Parameter Name	Setting Range	Default	Property
Group 12: Multi-Reference and Simple PLC Function				
12-00	Reference 0	-100.0%~100.0%	0.0%	☆
12-01	Reference 1	-100.0%~100.0%	0.0%	☆
12-02	Reference 2	-100.0%~100.0%	0.0%	☆
12-03	Reference 3	-100.0%~100.0%	0.0%	☆
12-04	Reference 4	-100.0%~100.0%	0.0%	☆
12-05	Reference 5	-100.0%~100.0%	0.0%	☆
12-06	Reference 6	-100.0%~100.0%	0.0%	☆
12-07	Reference 7	-100.0%~100.0%	0.0%	☆
12-08	Reference 8	-100.0%~100.0%	0.0%	☆
12-09	Reference 9	-100.0%~100.0%	0.0%	☆
12-10	Reference 10	-100.0%~100.0%	0.0%	☆
12-11	Reference 11	-100.0%~100.0%	0.0%	☆
12-12	Reference 12	-100.0%~100.0%	0.0%	☆
12-13	Reference 13	-100.0%~100.0%	0.0%	☆
12-14	Reference 14	-100.0%~100.0%	0.0%	☆
12-15	Reference 15	-100.0%~100.0%	0.0%	☆

Multi-reference can be the setting source of frequency, V/F separated voltage and process PID. The multi-reference is relative value and ranges from -100.0% to 100.0%.

As frequency source, it is a percentage relative to the maximum frequency. As V/F separated voltage source, it is a percentage relative to the rated motor voltage. As process PID setting source, it does not require conversion.

Multi-reference can be switched over based on different states of DI terminals. For details, see the descriptions of group P4.

Function Code	Parameter Name	Setting Range	Default	Property
Group 12: Multi-Reference and Simple PLC Function				
12-16	Simple PLC running mode	0: Stop after the AC drive runs one cycle 1: Keep final values after the AC drive runs one cycle 2: Repeat after the AC drive runs one cycle	0	☆



- 0: Stop after the AC drive runs one cycle

The AC drive stops after running one cycle, and will not start up until receiving another command.

- 1: Keep final values after the AC drive runs one cycle

The AC drive keeps the final running frequency and direction after running one cycle.

- 2: Repeat after the AC drive runs one cycle

The AC drive automatically starts another cycle after running one cycle, and will not stop until receiving the stop command.

Simple PLC can be either the frequency source or V/F separated voltage source.

When simple PLC is used as the frequency source, whether parameter values of 12-00 to 12-15 are positive or negative determines the running direction. If the parameter values are negative, it indicates that the AC drive runs in reverse direction.

Figure 6-32 Simple PLC when used as frequency source

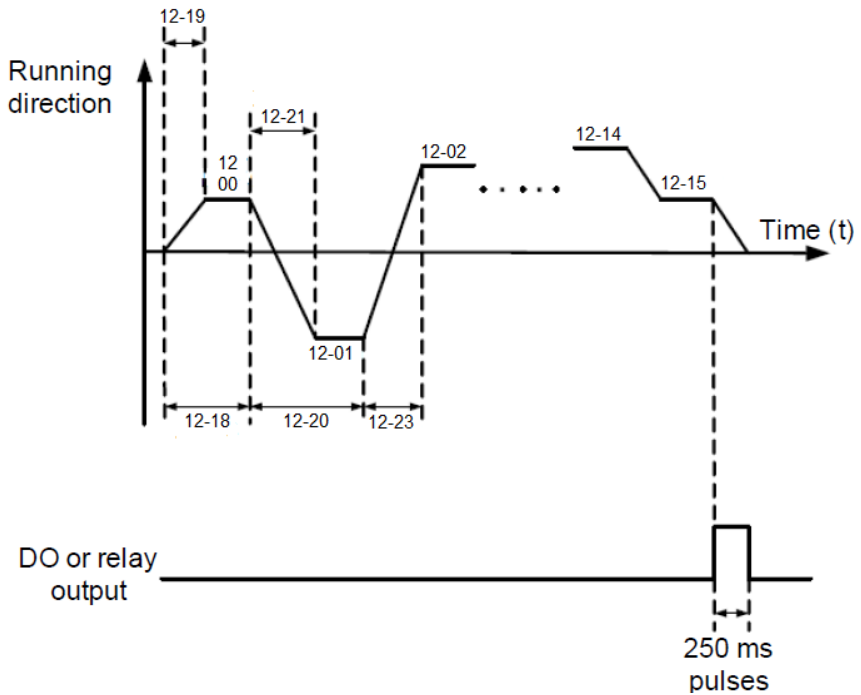

Function Code	Parameter Name	Setting Range	Default	Property
Group 12: Multi-Reference and Simple PLC Function				
12-17	Simple PLC retentive selection	Unit's digit (Retentive upon power failure)	00	☆
		0: No 1: Yes		
		Ten's digit (Retentive upon stop)		
		0: No 1: Yes		

PLC retentive upon power failure indicates that the AC drive memorizes the PLC running moment and running frequency before power failure and will continue to run from the memorized moment after it is powered on again. If the unit's digit is set to 0, the AC drive restarts the PLC process after it is powered on again.

PLC retentive upon stop indicates that the AC drive records the PLC running moment and running frequency upon stop and will continue to run from the recorded moment after it starts up again. If the ten's digit is set to 0, the AC drive restarts the PLC process after it starts up again.

Function Code	Parameter Name	Setting Range	Default
Group 12: Multi-Reference and Simple PLC Function			
12-18	Running time of simple PLC reference 0	0.0–6553.5s (h)	0.0s(h)
12-19	Acceleration/deceleration time of simple PLC reference 0	0–3	0
12-20	Running time of simple PLC reference 1	0.0–6553.5s (h)	0.0s(h)
12-21	Acceleration/deceleration time of simple PLC reference 1	0–3	0
12-22	Running time of simple PLC reference 2	0.0–6553.5s (h)	0.0s(h)
12-23	Acceleration/deceleration time of simple PLC reference 2	0–3	0
12-24	Running time of simple PLC reference 3	0.0–6553.5s (h)	0.0s(h)
12-25	Acceleration/deceleration time of simple PLC reference 3	0–3	0
12-26	Running time of simple PLC reference 4	0.0–6553.5s (h)	0.0s(h)
12-27	Acceleration/deceleration time of simple PLC reference 4	0–3	0
12-28	Running time of simple PLC reference 5	0.0–6553.5s (h)	0.0s(h)
12-29	Acceleration/deceleration time of simple PLC reference 5	0–3	0
12-30	Running time of simple PLC reference 6	0.0–6553.5s (h)	0.0s(h)
12-31	Acceleration/deceleration time of simple PLC reference 6	0–3	0
12-32	Running time of simple PLC reference 7	0.0–6553.5s (h)	0.0s(h)
12-33	Acceleration/deceleration time of simple PLC reference 7	0–3	0
12-34	Running time of simple PLC reference 8	0.0–6553.5s (h)	0.0s(h)
12-35	Acceleration/deceleration time of simple PLC reference 8	0–3	0
12-36	Running time of simple PLC reference 9	0.0–6553.5s (h)	0.0s(h)
12-37	Acceleration/deceleration time of simple PLC reference 9	0–3	0
12-38	Running time of simple PLC reference 10	0.0–6553.5s (h)	0.0s(h)
12-39	Acceleration/deceleration time of simple PLC reference 10	0–3	0
12-40	Running time of simple PLC reference 11	0.0–6553.5s (h)	0.0s(h)
12-41	Acceleration/deceleration time of simple PLC reference 11	0–3	0
12-42	Running time of simple PLC reference 12	0.0–6553.5s (h)	0.0s(h)
12-43	Acceleration/deceleration time of simple PLC reference 12	0–3	0
12-44	Running time of simple PLC reference 13	0.0–6553.5s (h)	0.0s(h)
12-45	Acceleration/deceleration time of simple PLC reference 13	0–3	0
12-46	Running time of simple PLC reference 14	0.0–6553.5s (h)	0.0s(h)
12-47	Acceleration/deceleration time of simple PLC reference 14	0–3	0
12-48	Running time of simple PLC reference 15	0.0–6553.5s (h)	0.0s(h)
12-49	Acceleration/deceleration time of simple PLC reference 15	0–3	0
12-50	Time unit of simple PLC running	0: s (second)1:h(hour)	0



Function Code	Parameter Name	Setting Range	Default	Property
Group 12: Multi-Reference and Simple PLC Function				
12-51	Reference 0 source	0: Set by 12-00 1: AI1 2: AI2 3: Reserved 4: Pulse setting 5: PID 6: Set by preset frequency (P0-08), modified via terminal UP/DOWN	0	☆

It determines the setting channel of reference 0. You can perform convenient switchover between the setting channels. When multi-reference or simple PLC is used as frequency source, the switchover between two frequency sources can be realized easily.

Group 13: Communication Parameters

Function Code	Parameter Name	Setting Range	Default
13-00	Data format	0: No check, data format <8,N,2> 1: Even parity check, data format <8,E,1> 2: Odd Parity check, data format <8,O,1> 3: No check, data format <8,N,1> Valid for Modbus	0
13-01	Baud rate	Unit's digit (Modbus baud rate) 0: 300 BPs 1: 600 BPs 2: 1200 BPs 3: 2400 BPs 4: 4800 BPs 5: 9600 BPs 6: 19200 BPs 7: 38400 BPs 8: 57600 BPs 9: 115200 BPs	6005
13-02	Local address	0: Broadcast address 1~247 Valid for Modbus	1
13-03	Response delay	0~20 ms Valid for Modbus	2 ms
13-04	Communication timeout	0.0s (invalid) 0.1~60.0s Valid for Modbus	0.0s
13-05	Modbus protocol selection	Unit's digit: Modbus protocol 0: Non-standard Modbus protocol 1: Standard Modbus protocol	30
13-06	Communication reading current resolution	0: 0.01A 1: 0.1A	0

Group 16: User Password

Function Code	Parameter Name	Setting Range	Default	Property
Group 16: Function Code Management				
16-00	User password	0-65535	0	☆

If it is set to any non-zero number, the password protection function is enabled. After a password has been set and taken effect, you must enter the correct password in order to enter the menu. If the entered password is incorrect you cannot view or modify parameters.

If 16-00 is set to 00000, the previously set user password is cleared, and the password protection function is disabled.



64

Function Code	Parameter Name	Setting Range	Default	Property
Group 16: Function Code Management				
16-01	Restore default settings	0: No operation 01: Restore factory settings except motor parameters 02: Clear records 04: Restore user backup parameters 501: Back up current user parameters	0	★

- 1: Restore default settings except motor parameters

If 16-01 is set to 1, most function codes are restored to the default settings except motor parameters, frequency reference resolution (P0-22), fault records, accumulative running time (P7-09), accumulative power-on time (P7-13) and accumulative power consumption (P7-14).

- 2: Clear records

If 16-01 is set to 2, the fault records, accumulative running time (P7-09), accumulative power-on time (P7-13) and accumulative power consumption (P7-14) are cleared.

- 501: Back up current user parameters

If 16-01 is set to 501, the current parameter settings are backed up, helping you to restore the setting if incorrect parameter setting is performed.

- 4: Restore user backup parameters

If 16-01 is set to 4, the previous backup user parameters are restored.

Group 17: Torque Control and Restricting Parameters

Function Code	Parameter Name	Setting Range	Default	Property
Group 17: Torque Control and Restricting Parameters				
17-00	Speed/Torque control selection	0: Speed control 1: Torque control	0	★

It is used to select the AC drive's control mode: speed control or torque control.

The SSI700 provides DI terminals with two torque related functions, function 29 (Torque control prohibited) and function 46 (Speed control/Torque control switchover). The two DI terminals need to be used together with 17-00 to implement speed control/torque control switchover.

If the DI terminal allocated with function 46 (Speed control/Torque control switchover) is OFF, the control mode is determined by 17-00. If the DI terminal allocated with function 46 is ON, the control mode is reverse to the value of 17-00.

However, if the DI terminal with function 29 (Torque control prohibited) is ON, the AC drive is fixed to run in the speed control mode.



Function Code	Parameter Name	Setting Range	Default	Property
Group 17: Torque Control and Restricting Parameters				
17-01	Torque setting source in torque control	0: Digital setting (17-03) 1: AI1 2: AI2 3: Reserved 4: Pulse setting (DI5) 5: Communication setting 6: MIN (AI1, AI2) 7: MAX (AI1, AI2) Full range of values 1–7 corresponds to the digital setting of 17-03.	0	★
17-03	Torque digital setting in torque control	-200.0%–200.0%	150.0 %	☆

17-01 is used to set the torque setting source. There are a total of eight torque setting sources.

The torque setting is a relative value. 100.0% corresponds to the AC drive's rated torque. The setting range is -200.0% to 200.0%, indicating the AC drive's maximum torque is twice of the AC drive's rated torque.

If the torque setting is positive, the AC drive rotates in forward direction. If the torque setting is negative, the AC drive rotates in reverse direction.

- 0: Digital setting (17-03)

The target torque directly uses the value set in 17-03.

- 1: AI1
- 2: AI2

The target torque is decided by analog input. The SSI900 control board provides two AI terminals (AI1, AI2). AI1 is 0–10 V voltage input, AI2 is 0–10 V voltage input or 4–20 mA current input decided by jumper J8 on the control board is -10 V to +10 V voltage input.

The SSI700 provides five curves indicating the mapping relationship between the input voltage of AI1, AI2 and the target frequency, three of which are linear (pointpoint) correspondence and two of which are four-point correspondence curves. You can set the curves by using function codes P4-13 to P4-27 and select curves for AI1, AI2 .

When AI is used as frequency setting source, the corresponding value 100% of voltage/ current input corresponds to the value of 17-03.

- 4: Pulse setting (DI5)

The target torque is set by DI5 (high-speed pulse). The pulse setting signal specification is 9–30 V (voltage range) and 0–100 kHz (frequency range). The pulse can only be input via DI5. The relationship (which is a two-point line) between DI5 input pulse frequency and the corresponding value is set in P4-28 to P4-31. The corresponding value 100.0% of pulse input corresponds to the value of 17-03.

- 5: Communication setting

The target torque is set by means of communication.

If the AC drive is a slave in point-point communication and receives data as torque source, data transmitted by the master is used as the setting value. For details, see the description of group 13.

In other conditions, data is given by host computer through the communication address 0x1000. The data format is -100.00% to 100.00%. 100% corresponds to the value of 17-03.

The SSI700 provides four communication and you can select one based on actual requirements.

66

Function Code	Parameter Name	Setting Range	Default	Property
Group 17: Torque Control and Restricting Parameters				
17-05	Forward maximum frequency in torque control	0.00 Hz to maximum frequency (P0-10)	50.00 Hz	☆
17-06	Reverse maximum frequency in torque control	0.00 Hz to maximum frequency (P0-10)	50.00 Hz	☆

two parameters are used to set the maximum frequency in forward or reverse rotation in torque control mode.

In torque control, if the load torque is smaller than the motor output torque, the motor's rotational speed will rise continuously. To avoid runaway of the mechanical system, the motor maximum rotating speed must be limited in torque control.

You can implement continuous change of the maximum frequency in torque control dynamically by controlling the frequency upper limit.

Function Code	Parameter Name	Setting Range	Default	Property
Group 17: Torque Control and Restricting Parameters				
17-07	Acceleration time in torque control	0.00–65000s	0.00s	☆
17-08	Deceleration time in torque control	0.00–65000s	0.00s	☆

In torque control, the difference between the motor output torque and the load torque determines the speed change rate of the motor and load. The motor rotational speed may change quickly and this will result in noise or too large mechanical stress. The setting of acceleration/deceleration time in torque control makes the motor rotational speed change softly.

However, in applications requiring rapid torque response, set the acceleration/deceleration time in torque control to 0.00s. For example, two AC drives are connected to drive the same load. To balance the load allocation, set one AC drive as master in speed control and the other as slave in torque control. The slave receives the master's output torque as the torque command and must follow the master rapidly. In this case, the acceleration/deceleration time of the slave in torque control is set to 0.0s.

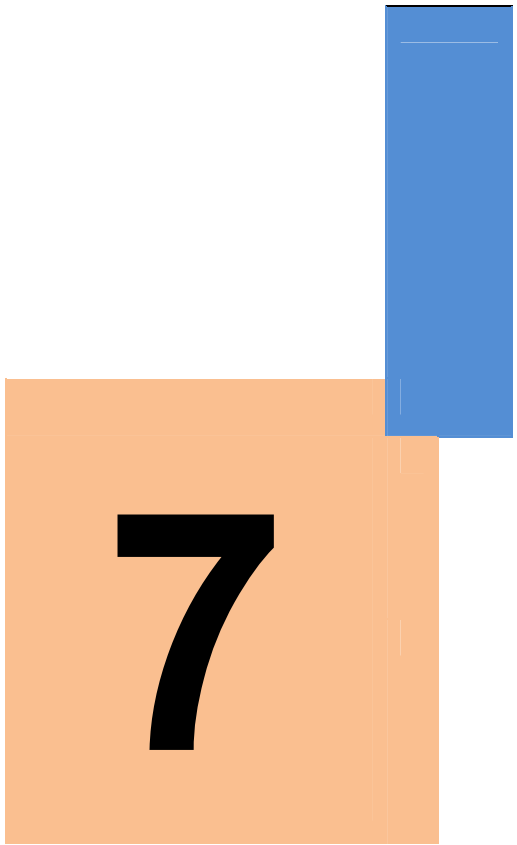

EMC

Chapter 7 EMC

7.1 Definition of Terms

1) EMC

Electromagnetic compatibility (EMC) describes the ability of electronic and electrical devices or systems to work properly in the electromagnetic environment and not to generate electromagnetic interference that influences other local devices or systems.

In other words, EMC includes two aspects: The electromagnetic interference generated by a device or system must be restricted within a certain limit; the device or system must have sufficient immunity to the electromagnetic interference in the environment.

2) First environment

Environment that includes domestic premises, it also includes establishments directly connected without intermediate transformers to a low-voltage power supply network which supplies buildings used for domestic purposes

3) Second environment

Environment that includes all establishments other than those directly connected to a low-voltage power supply network which supplies buildings used for domestic purposes

4) Category C1 AC drive

Power Drive System (PDS) of rated voltage less than 1000 V, intended for use in the first environment

5) Category C2 AC drive

PDS of rated voltage less than 1000 V, which is neither a plug in device nor a movable device and, when used in the first environment, is intended to be installed and commissioned only by a professional

6) Category C3 AC drive

PDS of rated voltage less than 1000 V, intended for use in the second environment and not intended for use in the first environment

7) Category C4 AC drive

PDS of rated voltage equal to or above 1000 V, or rated current equal to or above 400 A, or intended for use in complex systems in the second environment

7.2 Introduction to EMC Standard

7.2.1 EMC Standard

The SSI700 series AC drive satisfies the requirements of standard EN 61800-3: 2004 Category C2. The AC drives are applied to both the first environment and the second environment.

7.2.2 Installation Environment

The system manufacturer using the AC drive is responsible for compliance of the system with the European EMC directive. Based on the application of the system, the integrator must ensure that the system complies with standard EN 61800-3: 2004 Category C2, C3 or C4.

Warning

If applied in the first environment, the AC drive may generate radio interference. Besides the CE compliance described in this chapter, users must take measures to avoid such interference, if necessary.

7.3 Selection of Peripheral EMC Devices

2

7.3.1 Installation of EMC Input Filter on Power Input Side

An EMC filter installed between the AC drive and the power supply can not only restrict the interference of electromagnetic noise in the surrounding environment on the AC drive, but also prevents the interference from the AC drive on the surrounding equipment.

The SSI700 series AC drive satisfies the requirements of category C2 only with an EMC filter installed on the power input side. The installation precautions are as follows:

- Strictly comply with the ratings when using the EMC filter. The EMC filter is category I electric apparatus, and therefore, the metal housing ground of the filter should be in good contact with the metal ground of the installation cabinet on a large area, and requires good conductive continuity. Otherwise, it will result in electric shock or poor EMC effect.
- The ground of the EMC filter and the PE conductor of the AC drive must be tied to the same common ground. Otherwise, the EMC effect will be affected seriously.
- The EMC filter should be installed as closely as possible to the power input side of the AC drive.

The following table lists the recommended manufacturers and models of EMC filters for the SSI700 series AC drive. Select a proper one based on actual requirements.

7.3.2 Installation of AC Input Reactor on Power Input Side

An AC input reactor is installed to eliminate the harmonics of the input current. As an optional device, the reactor can be installed externally to meet strict requirements of an application environment for harmonics. The following table lists the recommended manufacturers and models of input reactors.

7.3.3 Installation of AC Output Reactor on Power Output Side

Whether to install an AC output reactor on the power output side is dependent on the actual situation. The cable connecting the AC drive and the motor should not be too long; capacitance enlarges when an over-long cable is used and thus high-harmonics current may be easily generated.

If the length of the output cable is equal to or greater than the value in the following table, install an AC output reactor on the power output side of the AC drive.

Table 7-1 Cable length threshold when an AC output reactor is installed

AC Drive Power (kW)	Rated Voltage (V)	Cable Length Threshold (m)
≥4KW	200~500V	50M

Table 7-2 Recommended manufacturers and models of EMC filters & AC Input Reactor & AC Output Reactor

AC Drive Model	Rated Input Current	AC Input Filter Model	AC Input Reactor Model	Rated Output Current	AC Output Reactor Model
Three-phase 380~440V 50/60HZ					
SSI707G43A	3.4A	NFI-005	ACL-0005	2.1A	OCL-0005
SSI715G43A	5A	NFI-005	ACL-0007	3.8A	OCL-0005
SSI722G43A	5.8A	NFI-010	ACL-0007	5.1A	OCL-0007

7.4 Shielded Cable

3

7.4.1 Requirements for Shielded Cable

The shielded cable must be used to satisfy the EMC requirements of CE marking. Shielded cables are classified into three-conductor cable and four-conductor cable. If conductivity of the cable shield is not sufficient, add an independent PE cable, or use a four-conductor cable, of which one phase conductor is PE cable.

The three-conductor cable and four-conductor cable are shown in the following figure.

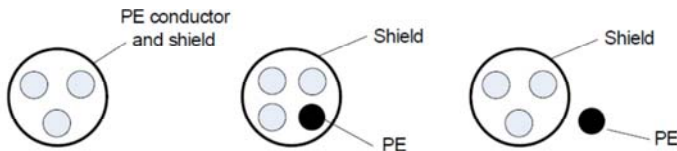

To suppress emission and conduction of the radio frequency interference effectively, the shield of the shielded cable is cooper braid. The braided density of the cooper braid should be greater than 90% to enhance the shielding efficiency and conductivity, as shown in the following figure.

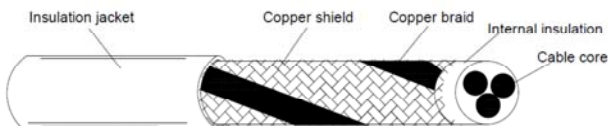

The following figure shows the grounding method of the shielded cable.

Figure 7-1 Grounding of the shielded cable

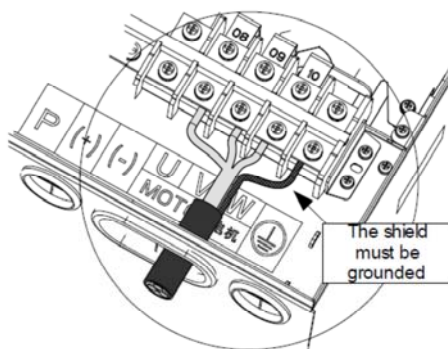

The installation precautions are as follows:

- Symmetrical shielded cable is recommended. The four-conductor shielded cable can also be used as an input cable.
- The motor cable and PE shielded conducting wire (twisted shielded) should be as short as possible to reduce electromagnetic radiation and external stray current and capacitive current of the cable. If the motor cable is over 100 meters long, an output filter or reactor is required.
- It is recommended that all control cables be shielded.
- It is recommended that a shielded cable be used as the output power cable of the AC drive; the cable shield must be well grounded. For devices suffering from interference, shielded twisted pair (STP) cable is recommended as the lead wire and the cable shield must be well grounded

7.4.2 Cabling Requirements

4

- 1) The motor cables must be laid far away from other cables. The motor cables of several AC drives can be laid side by side.
- 2) It is recommended that the motor cables, power input cables and control cables be laid in different ducts. To avoid electromagnetic interference caused by rapid change of the output voltage of the AC drive, the motor cables and other cables must not be laid side by side for a long distance.
- 3) If the control cable must run across the power cable, make sure they are arranged at an angle of close to 90° . Other cables must not run across the AC drive.
- 4) The power input and output cables of the AC drive and weak-current signal cables (such as control cable) should be laid vertically (if possible) rather than in parallel.
- 5) The cable ducts must be in good connection and well grounded. Aluminium ducts can be used to improve electric potential.
- 6) The filter, AC drive and motor should be connected to the system (machinery or appliance) properly, with spraying protection at the installation part and conductive metal in full contact.

Figure 7-2 Cabling diagram

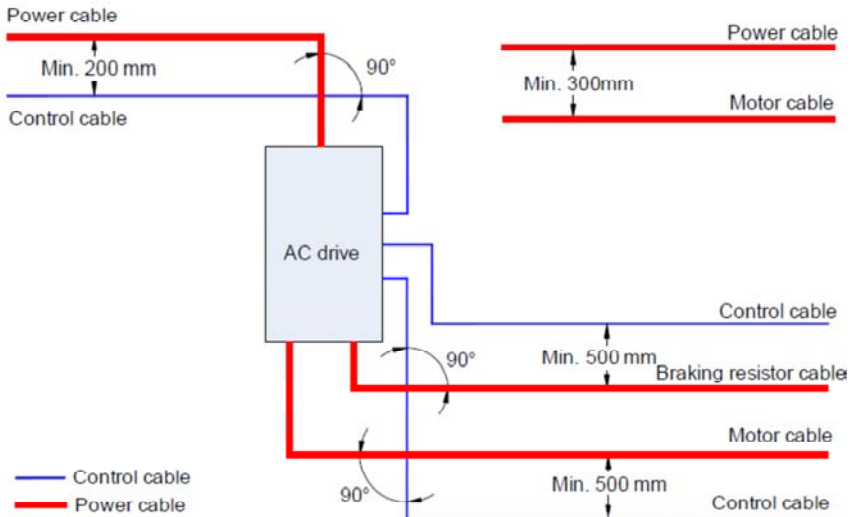

7.5 Solutions to Common EMC Interference Problems

5

The AC drive generates very strong interference. Although EMC measures are taken, the interference may still exist due to improper cabling or grounding during use. When the AC drive interferes with other devices, adopt the following solutions.

Interference Type	Solution
Leakage protection switch tripping	<ul style="list-style-type: none"> • Connect the motor housing to the PE of the AC drive. • Connect the PE of the AC drive to the PE of the mains power supply. • Add a safety capacitor to the power input cable. • Add magnetic rings to the input drive cable.
AC drive interference during running	<ul style="list-style-type: none"> • Connect the motor housing to the PE of the AC drive. • Connect the PE of the AC drive to the PE of the mains voltage. • Add a safety capacitor to the power input cable and wind the cable with magnetic rings. • Add a safety capacitor to the interfered signal port or wind the signal cable with magnetic rings. • Connect the equipment to the common ground.
Communication interference	<ul style="list-style-type: none"> • Connect the motor housing to the PE of the AC drive. • Connect the PE of the AC drive to the PE of the mains voltage. • Add a safety capacitor to the power input cable and wind the cable with magnetic rings. • Add a matching resistor between the communication cable source and the load side. • Add a common grounding cable besides the communication cable. • Use a shielded cable as the communication cable and connect the cable shield to the common grounding point.
I/O interference	<ul style="list-style-type: none"> • Enlarge the capacitance at the low-speed DI. A maximum of 0.11μF capacitance is suggested. • Enlarge the capacitance at the AI. A maximum of 0.22 μF is Suggested.

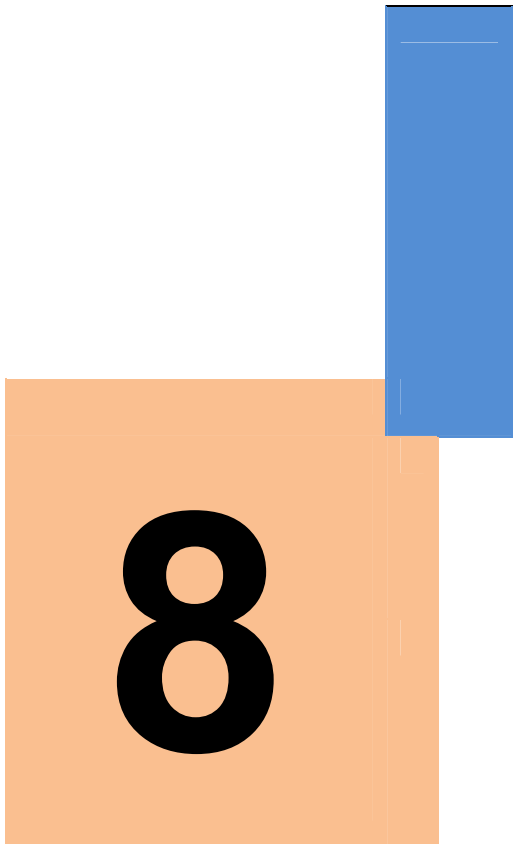

Selection and Dimensions

Chapter 8 Selection and Dimensions

8.1 Electrical Specifications of the SSI700

Table 8-1 Models and technical data of the SSI700

AC Drive Model	Power Capacity (kVA)	Rated Input Current	Rated Output Current	Adaptable Motor (KW, HP)	Thermal Power Consumption (kW)
Three-phase 220V 50/60HZ					
SSI704G23A	0.7	3.4A	2.1A	0.4KW	0.027
SSI707G23A	1.5	5A	3.8A	0.75 KW	0.050
SSI715G23A	3	5.8A	5.1A	1.5 KW	0.066
Three-phase 380V 50/60HZ					
SSI707G43A	1.5	3.4A	2.1A	0.75 KW	0.027
SSI715G43A	3	5A	3.8A	1.5 KW	0.050
SSI722G43A	4	5.8A	5.1A	2.2 KW	0.066

8.2 Physical Appearance and Overall Dimensions of the SSI700

Figure 8-1 Physical appearance and overall dimensions of the SSI700 (plastic housing)

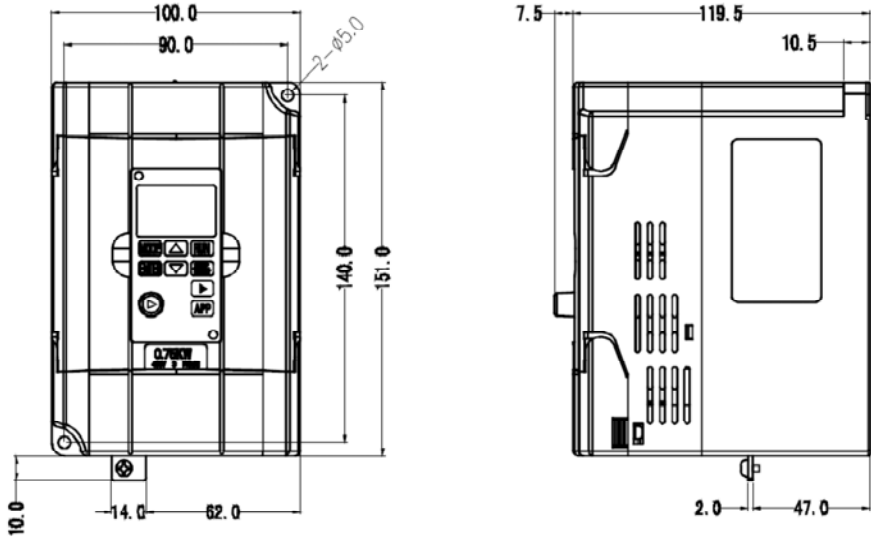

8.3 Physical Dimensions of External Operation Panel

2

Figure 8-3 Physical dimensions of external operation panel

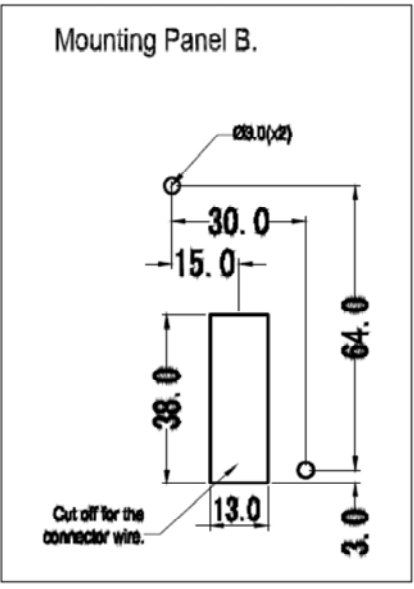
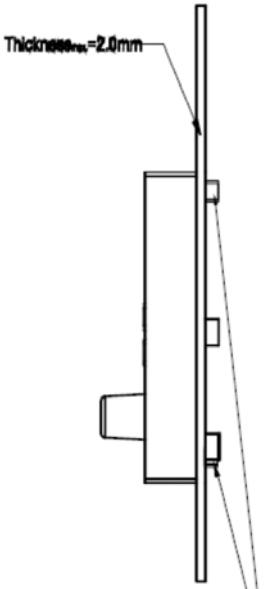
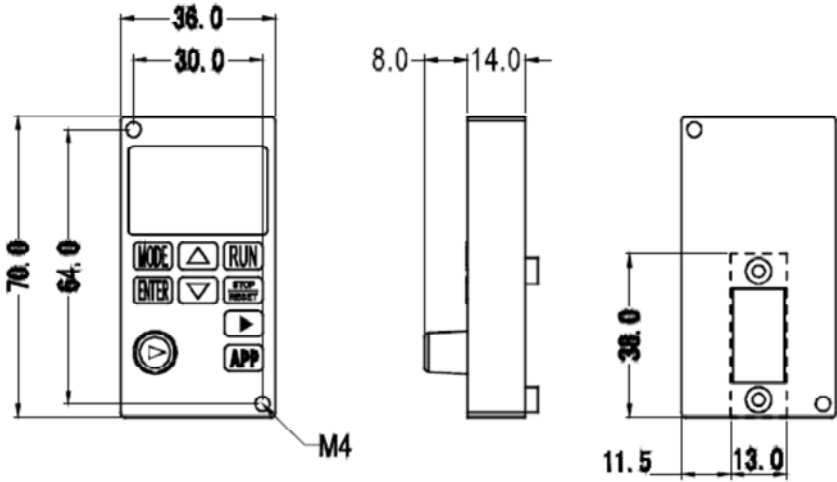

Must Add Nut M2*P0.4(X2)
(Nut is not available by Delta)

8.4 Selection of Braking Unit and Braking Resistor

3

8.4.1 Physical Dimensions of External Braking Resistor

The motor and load's regenerative energy is almost completely consumed on the braking resistor when braking.

According to the formula $U \times U/R = P_b$:

- U refers to the braking voltage at system stable braking.

Different systems select different braking voltages. The 380 VAC system usually selects 700 V braking voltage.

- P_b refers to the braking power.

8.3.2 Selection of Power of Braking Resistor

In theory, the power of the braking resistor is consistent with the braking power. But in consideration that the de-rating is 70%, you can calculate the power of the braking resistor according to the formula $0.7 \times P_r = P_b \times D$.

- P_r refers to the power of resistor.
- D refers to the braking frequency (percentage of the regenerative process to the whole working process)

Application	Elevator	Winding and unwinding	Centrifuge	Occasional braking load	General application
Braking Frequency	20%–30%	20%–30%	50%–60%	5%	10%

Table 8-4 below provides data for reference. You can select different resistance and power based on actual needs. However, the resistance must not be lower than the recommended value. The power may be higher than the recommended value.

The braking resistor model is dependent on the generation power of the motor in the actual system and is also related to the system inertia, deceleration time and potential energy load. For systems with high inertia, and/or rapid deceleration times, or frequent braking sequences, the braking resistor with higher power and lower resistance value should be selected.

Table 5 Recommended values of braking resistor

AC Drive Model	Recommended Power	Recommended Resistance	Braking Unit	Remark
SSI704G23A	80W	$\geq 200 \Omega$	Built-in (standard)	No special description
SSI707G23A	80W	$\geq 200 \Omega$		
SSI715G23A	300W	$\geq 100 \Omega$		
SSI707G43A	80W	$\geq 750 \Omega$		
SSI715G43A	300W	$\geq 400 \Omega$		
SSI722G43A	300W	$\geq 250 \Omega$		

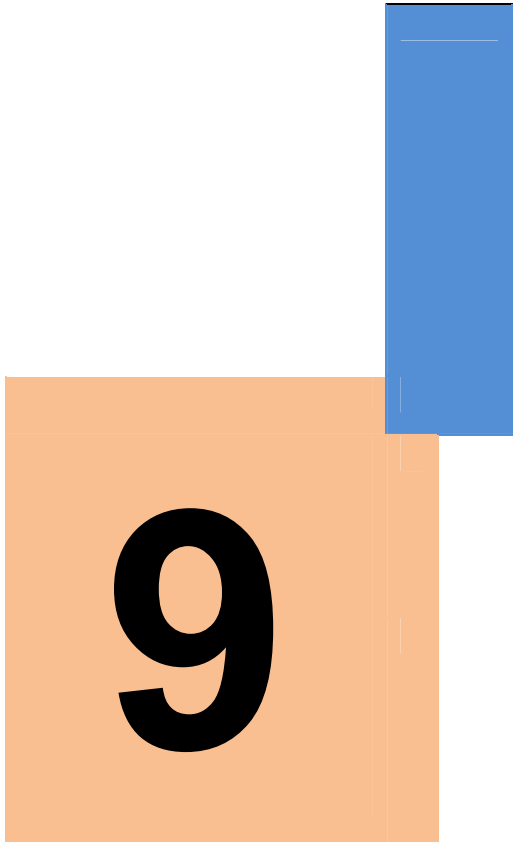

Maintenance and Troubleshooting

Chapter 9 Maintenance and Troubleshooting

9.1 Routine Repair and Maintenance of the SSI700

9.1.1 Routine Maintenance

The influence of the ambient temperature, humidity, dust and vibration will cause the aging of the devices in the AC drive, which may cause potential faults or reduce the service life of the AC drive. Therefore, it is necessary to carry out routine and periodic maintenance.

Routine maintenance involves checking:

- Whether the motor sounds abnormally during running
- Whether the motor vibrates excessively during running
- Whether the installation environment of the AC drive changes.
- Whether the AC drive's cooling fan works normally
- Whether the AC drive overheats

Routine cleaning involves:

- Keep the AC drive clean all the time.
- Remove the dust, especially metal powder on the surface of the AC drive, to prevent the dust from entering the AC drive.
- Clear the oil stain on the cooling fan of the AC drive.

9.1.2 Periodic Inspection

Perform periodic inspection in places where inspection is difficult.

Periodic inspection involves:

Check and clean the air duct periodically.

Check whether the screws become loose.

Check whether the AC drive is corroded.

Check whether the wiring terminals show signs of arcing;

Main circuit insulation test

Before measuring the insulating resistance with megameter (500 VDC megameter recommended), disconnect the main circuit from the AC drive.

Do not use the insulating resistance meter to test the insulation of the control circuit. The high voltage test need not be performed again because it has been completed before delivery.

Prompt

9.1.3 Replacement of Vulnerable Components

The vulnerable components of the AC drive are cooling fan and filter electrolytic capacitor. Their service life is related to the operating environment and maintenance status. Generally, the service life is shown as follows:

Component	Service Life	Possible Damage Reason	Judging Criteria
Fan	2 to 3 years	<ul style="list-style-type: none"> • Bearing worn • Blade aging 	<ul style="list-style-type: none"> • Whether there is crack on the blade • Whether there is abnormal vibration noise upon startup



Component	Service Life	Possible Damage Reason	Judging Criteria
Electrolytic capacitor	4 to 5 years	<ul style="list-style-type: none"> • Input power supply in poor quality • High ambient temperature • Frequent load jumping • Electrolytic aging 	<ul style="list-style-type: none"> • Whether there is liquid leakage. • Whether the safe valve has projected. • Measure the static capacitance. • Measure the insulating resistance.

9.1.4 Storage of the AC Drive

For storage of the AC drive, pay attention to the following two aspects:

- 1) Pack the AC drive with the original packing box provided by SSINVERTER.
- 2) Long-term storage degrades the electrolytic capacitor. Thus, the AC drive must be energized once every 2 years, each time lasting at least 5 hours. The input voltage must be increased slowly to the rated value with the regulator.

9.2 Warranty Agreement

- 1) Free warranty only applies to the AC drive itself.
- 2) SSINVERTER will provide 18-month warranty (starting from the leave-factory date as indicated on the barcode) for the failure or damage under normal use conditions. If the equipment has been used for over 18 months, reasonable repair expenses will be charged.
- 3) Reasonable repair expenses will be charged for the damages due to the following causes:
 - Improper operation without following the instructions
 - Fire, flood or abnormal voltage.
 - Using the AC drive for non-recommended function
- 4) The maintenance fee is charged according to SSINVERTER'S uniform standard. If there is an agreement, the agreement prevails.

9.3 Faults and Solutions

The SSI700 provides a total of 24 pieces of fault information and protective functions. After a fault occurs, the AC drive implements the protection function, and displays the fault code on the operation panel (if the operation panel is available).

Before contacting SSINVERTER for technical support, you can first determine the fault type, analyze the causes, and perform troubleshooting according to the following tables. If the fault cannot be rectified, contact the agent or SSINVERTER. EH is the AC drive hardware overcurrent or overvoltage signal. In most situations, hardware overvoltage fault causes EH.

Figure 9-1 Solutions to the faults of the SSI900

Fault Name	Display	Possible Causes	Solutions
Inverter unit protection	SC	1: The output circuit is grounded or short circuited. 2: The connecting cable of the motor is too long. 3: The module overheats. 4: The internal connections become loose. 5: The main control board is faulty. 6: The drive board is faulty. 7: The inverter module is faulty.	1: Eliminate external faults. 2: Install a reactor or an output filter. 3: Check the air filter and the cooling fan. 4: Connect all cables properly. 5: Contact the agent or Ssinverter.

Fault Name	Display	Possible Causes	Solutions
Overcurrent during acceleration	OCA	<ol style="list-style-type: none"> 1: The output circuit is grounded or short circuited. 2: Motor auto-tuning is not performed. 3: The acceleration time is too short. 4: Manual torque boost or V/F curve is not appropriate. 5: The voltage is too low. 6: The startup operation is performed on the rotating motor. 7: A sudden load is added during acceleration. 8: The AC drive model is of too small power class. 	<ol style="list-style-type: none"> 1: Eliminate external faults. 2: Perform the motor autotuning. 3: Increase the acceleration time. 4: Adjust the manual torque boost or V/F curve. 5: Adjust the voltage to normal range. 6: Select rotational speed tracking restart or start the motor after it stops. 7: Remove the added load. 8: Select an AC drive of higher power class.
Overcurrent during deceleration	OCD	<ol style="list-style-type: none"> 1: The output circuit is grounded or short circuited. 2: Motor auto-tuning is not performed. 3: The deceleration time is too short. 4: The voltage is too low. 5: A sudden load is added during deceleration. 6: The braking unit and braking resistor are not installed. 	<ol style="list-style-type: none"> 1: Eliminate external faults. 2: Perform the motor autotuning. 3: Increase the deceleration time. 4: Adjust the voltage to normal range. 5: Remove the added load. 6: Install the braking unit and braking resistor.
Overcurrent at constant speed	OCN	<ol style="list-style-type: none"> 1: The output circuit is grounded or short circuited. 2: Motor auto-tuning is not performed. 3: The voltage is too low. 4: A sudden load is added during operation. 5: The AC drive model is of too small power class. 	<ol style="list-style-type: none"> 1: Eliminate external faults. 2: Perform the motor autotuning. 3: Adjust the voltage to normal range. 4: Remove the added load. 5: Select an AC drive of higher power class.
Overvoltage during acceleration	OUA	<ol style="list-style-type: none"> 1: The input voltage is too high. 2: An external force drives the motor during acceleration. 3: The acceleration time is too short. 4: The braking unit and braking resistor are not installed. 	<ol style="list-style-type: none"> 1: Adjust the voltage to normal range. 2: Cancel the external force or install a braking resistor. 3: Increase the acceleration time. 4: Install the braking unit and braking resistor.
Overvoltage during deceleration	OUD	<ol style="list-style-type: none"> 1: The input voltage is too high. 2: An external force drives the motor during deceleration. 3: The deceleration time is too short. 4: The braking unit and braking resistor are not installed. 	<ol style="list-style-type: none"> 1: Adjust the voltage to normal range. 2: Cancel the external force or install the braking resistor. 3: Increase the deceleration time. 4: Install the braking unit and braking resistor.
Overvoltage at constant speed	OUN	<ol style="list-style-type: none"> 1: The input voltage is too high. 2: An external force drives the motor during deceleration. 	<ol style="list-style-type: none"> 1: Adjust the voltage to normal range. 2: Cancel the external force or install the braking resistor.
Control power supply fault	UU	The input voltage is not within the allowable range.	Adjust the input voltage to the allowable range.
External equipment fault	EF	<ol style="list-style-type: none"> 1: External fault signal is input via DI. 2: External fault signal is input via virtual I/O. 	Reset the operation.

Fault Name	Display	Possible Causes	Solutions
Undervoltage	LU	<ol style="list-style-type: none"> 1: Instantaneous power failure occurs on the input power supply. 2: The AC drive's input voltage is not within the allowable range. 3: The bus voltage is abnormal. 4: The rectifier bridge and buffer resistor are faulty. 5: The drive board is faulty. 6: The main control board is faulty. 	<ol style="list-style-type: none"> 1: Reset the fault. 2: Adjust the voltage to normal range. 3: Contact the agent or Ssinverter.
AC drive overload	OL2	<ol style="list-style-type: none"> 1: The load is too heavy or locked rotor occurs on the motor. 2: The AC drive model is of too small power class. 	<ol style="list-style-type: none"> 1: Reduce the load and check the motor and mechanical condition. 2: Select an AC drive higher power class.
Motor overload	OL1	<ol style="list-style-type: none"> 1: P9-01 is set improperly. 2: The load is too heavy or locked rotor occurs on the motor. 3: The AC drive model is of too small power class. 	<ol style="list-style-type: none"> 1: Set P9-01 correctly. 2: Reduce the load and check the motor and the mechanical condition. 3: Select an AC drive of higher power class.
Module overheat	OH1	<ol style="list-style-type: none"> 1: The ambient temperature is too high. 2: The air filter is blocked. 3: The fan is damaged. 4: The thermally sensitive resistor of the module is damaged. 5: The inverter module is damaged. 	<ol style="list-style-type: none"> 1: Lower the ambient temperature. 2: Clean the air filter. 3: Replace the damaged fan. 4: Replace the damaged thermally sensitive resistor. 5: Replace the inverter module.
Communication fault	CE	<ol style="list-style-type: none"> 1: The host computer is in abnormal state. 2: The communication cable is faulty. 3: P0-28 is set improperly. 4: The communication parameters in group "13" are set improperly. 	<ol style="list-style-type: none"> 1: Check the cabling of host computer. 2: Check the communication cabling. 3: Set P0-28 correctly. 4: Set the communication parameters properly.
Contacting fault	RL	<ol style="list-style-type: none"> 1: The drive board and power supply are faulty. 2: The contactor is faulty. 	<ol style="list-style-type: none"> 1: Replace the faulty drive board or power supply board. 2: Replace the faulty contactor.
Current detection fault	CC	<ol style="list-style-type: none"> 1: The HALL device is faulty. 2: The drive board is faulty. 	<ol style="list-style-type: none"> 1: Replace the faulty HALL device. 2: Replace the faulty drive board.
Motor auto-tuning fault	ER	<ol style="list-style-type: none"> 1: The motor parameters are not set according to the nameplate. 2: The motor auto-tuning times out. 	<ol style="list-style-type: none"> 1: Set the motor parameters according to the nameplate properly. 2: Check the cable the AC drive and the motor.
EEPROM readwrite fault	EP	The EEPROM chip is damaged.	Replace the main control board.
AC drive hardware fault	EH	<ol style="list-style-type: none"> 1: Overvoltage exists. 2: Overcurrent exists. 	<ol style="list-style-type: none"> 1: Handle based on overvoltage. 2: Handle based on overcurrent.
Short circuit to Ground	GF	The motor is short circuited to the ground.	Replace the cable or motor.
Accumulative running time reached	OT	The accumulative running time reaches the setting value.	Clear the record through the parameter initialization function.



Fault Name	Display	Possible Causes	Solutions
Accumulative power-on time reached	UT	The accumulative power-on time reaches the setting value.	Clear the record through the parameter initialization function.
Load(loss) becoming 0	LL	The AC drive running current is lower than P9-64.	Check that the load is disconnected or the setting of P9-64 and P9-65 is correct.
PID feedback lost during running	PD	The PID feedback is lower than the setting of 10-26.	Check the PID feedback signal or set 10-26 to a proper value.
Motor overheat	OH2	1: The cabling of the temperature sensor becomes loose. 2: The motor temperature is too high.	1: Check the temperature sensor cabling and eliminate the cabling fault. 2: Lower the carrier frequency or adopt other heat radiation measures.

9.4 Common Faults and Solutions

You may come across the following faults during the use of the AC drive. Refer to the following table for simple fault analysis.

Table 9-2 Troubleshooting to common faults of the AC drive

SN	Fault	Possible Causes	Solutions
1	There is no display at power-on	1: There is no power supply to the AC drive or the power input to the AC drive is too low. 2: The power supply of the switch on the drive board of the AC drive is faulty. 3: The rectifier bridge is damaged. 4: The control board or the operation panel is faulty. 5: The cable connecting the control board and the drive board and the operation panel breaks.	1: Check the power supply. 2: Check the bus voltage. 3: Re-connect the 8-core and 28-core cables. 4: Contact the agent or Ssinverter for technical support.
2	"HC" is displayed at power-on.	1: The cable between the drive board and the control board is in poor contact. 2: Related components on the control board are damaged. 3: The motor or the motor cable is short circuited to the ground. 4: The HALL device is faulty. 5: The power input to the AC drive is too low.	1: Re-connect the 8-core and 28-core cables. 2: Contact the agent or Ssinverter for technical support.
3	"GF" is displayed at power-on.	1: The motor or the motor output cable is short-circuited to the ground. 2: The AC drive is damaged.	1: Measure the insulation of the motor and the output cable with a megger. 2: Contact the agent or Ssinverter for technical support.
4	The AC drive display is normal upon poweron. But "HC" is displayed after running and stops immediately.	1: The cooling fan is damaged or locked-rotor occurs. 2: The external control terminal cable is short circuited.	1: Replace the damaged fan. 2: Eliminate external fault.

SN	Fault	Possible Causes	Solutions
5	OH1 (module overheat) fault is reported frequently.	<ol style="list-style-type: none"> 1: The setting of carrier frequency is too high. 2: The cooling fan is damaged, or the air filter is blocked. 3: Components inside the AC drive are damaged (thermal coupler or others). 	<ol style="list-style-type: none"> 1: Reduce the carrier frequency (PO-15). 2: Replace the fan and clean the air filter. 3: Contact the agent or Ssinverter for technical support.
6	The motor does not rotate after the AC drive runs.	<ol style="list-style-type: none"> 1: Check the motor and the motor cables. 2: The AC drive parameters are set improperly (motor parameters). 3: The cable between the drive board and the control board is in poor contact. 4: The drive board is faulty. 	<ol style="list-style-type: none"> 1: Ensure the cable between the AC drive and the motor is normal. 2: Replace the motor or clear mechanical faults. 3: Check and re-set motor parameters.
7	The DI terminals are disabled.	<ol style="list-style-type: none"> 1: The parameters are set incorrectly. 2: The external signal is incorrect. 3: The jumper bar across OP and +24 V becomes loose. 4: The control board is faulty. 	<ol style="list-style-type: none"> 1: Check and reset the parameters in group P4. 2: Re-connect the external signal cables. 3: Re-confirm the jumper bar across OP and +24 V. 4: Contact the agent or Ssinverter for technical support.
8	The motor speed is always low in CLVC mode.	<ol style="list-style-type: none"> 1: The encoder is faulty. 2: The encoder cable is connected incorrectly or in poor contact. 3: The PG card is faulty. 4: The drive board is faulty. 	<ol style="list-style-type: none"> 1: Replace the encoder and ensure the cabling is proper. 2: Replace the PG card. 3: Contact the agent or Ssinverter for technical support.
9	The AC drive reports overcurrent and overvoltage frequently.	<ol style="list-style-type: none"> 1: The motor parameters are set improperly. 2: The acceleration/deceleration time is improper. 3: The load fluctuates. 	<ol style="list-style-type: none"> 1: Re-set motor parameters or re-perform the motor autotuning. 2: Set proper acceleration/ deceleration time. 3: Contact the agent or Ssinverter for technical support.
10	"RL" is reported upon power-on or running.	The soft startup contactor is not picked up.	<ol style="list-style-type: none"> 1: Check whether the contactor cable is loose. 2: Check whether the contactor is faulty. 3: Check whether 24 V power supply of the contactor is faulty. 4: Contact the agent or Ssinverter for technical support.
11	8.8.8.8.8 is displayed upon power-on.	Related component on the control board is damaged.	Replace the control board.

Warranty Agreement

1. The warranty period of the product is 18 months (refer to the barcode on the equipment). During the warranty period, if the product fails or is damaged under the condition of normal use by following the instructions, Ssinverter will be responsible for free maintenance.
2. Within the warranty period, maintenance will be charged for the damages caused by the following reasons:



- a. Improper use or repair/modification without prior permission
 - b. Fire, flood, abnormal voltage, other disasters and secondary disaster
 - c. Hardware damage caused by dropping or transportation after procurement
 - d. Improper operation
 - e. Trouble out of the equipment (for example, external device)
3. If there is any failure or damage to the product, please correctly fill out the Product Warranty Card in detail.
 4. The maintenance fee is charged according to the latest Maintenance Price List of Ssinverter.
 5. The Product Warranty Card is not re-issued. Please keep the card and present it to the maintenance personnel when asking for maintenance.
 6. If there is any problem during the service, contact Ssinverter's agent or Ssinverter directly.
 7. This agreement shall be interpreted by Ssinverter Co., Ltd.

Website: www.ssinverter.info

Warranty and production control no

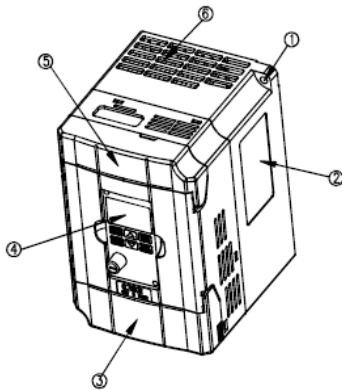

Nameplate 2	
AC drive model	MODEL SSI715G23A
Rated input	INPUT 3PH AC 220V 50/60HZ
Rated output	OUTPUT 3PH AC 0~110% V Input 0~3200HZ
Power class	POWER 5.1A 1.5KW
Manufacturing SN	1715C13103A www.ssinverter.com

SSI700 Series AC drive	17	15		
Mark	04	07	15	22
Adaptable Motor(KW)	0.4	0.75	1.5	2.2

C	13	10	3A	Production Series
Country of manufacturer				Production Week
T Taiwan				Production Year
C China				